

TELEVISION ENGINEERING



APRIL, 1952

*Absorbed by
Radio Communication*

ENGINEERING

The News-Engineering Journal of VHF-UHF TV, Radar and Allied Industries



*1 and 10-Kw Transmitting
Components and Tubes
Reviewed at UHF Symposium*

The Ideal Dielectric

FOR NEW **UHF-TV** APPLICATIONS

MYCALEX

Glass-Bonded Mica
INSULATION

**- for low loss
at low cost!**

- LOW-LOSS FROM 60 CYCLES/SECOND TO 24,000 MEGACYCLES/SECOND
- MAXIMUM EFFICIENCY, UTMOST ADAPTABILITY, LOWEST COST
- AVAILABLE MOLDED TO PRACTICALLY ANY SHAPE OR SIZE WITH OR WITHOUT METAL ELECTRODES OR INSERTS

FCC Approval of UHF TV has introduced an era of engineering and manufacture to standards seldom before attained in mass production. Many materials, dielectrics in particular, fail to meet these more critical requirements. MYCALEX 410 is one exception. This dielectric can be molded to close tolerances with or without metal inserts—high efficiency to well over 24,000 megacycles. MYCALEX 410 can be molded in volume at low cost. It can be produced to closer tolerances than higher priced ceramics. Electrically and mechanically, MYCALEX 410 is the ideal dielectric for tube sockets, tuners, condensers, switches, coil structures and many other UHF components.

CHARACTERISTICS OF MYCALEX GRADE 410

Power factor, 1 megacycle	0.0015
Dielectric constant, 1 megacycle	9.2
Loss factor, 1 megacycle	0.014
Dielectric strength, volts/mil	400
Volume resistivity, ohm-cm	1×10^{15}
Arc resistance, seconds	250
Impact strength, Izod, ft.-lb./in. of notch	0.7
Maximum safe operating temperature, °C	350
Maximum safe operating temperature, °F	650
Water absorption % in 24 hours	nil
Coefficient of linear expansion, °C	11×10^{-6}
Tensile strength, psi	6000

WRITE FOR 20-PAGE CATALOG
This comprehensive compilation of technical and manufacturing data includes complete dielectric information.

TUBE SOCKETS

MYCALEX glass-bonded mica sockets are injection molded to extremely close tolerance. This exclusive process affords superior low-loss properties, exceptional uniformity and results in a socket of comparable quality but greater dimensional accuracy than ceramics—all at no greater cost than inferior phenolic types. These sockets are available in two grades, featuring high dielectric strength, low dielectric loss, high arc resistance and fully meet RTMA standards.

Write for Tube Socket Data Sheets



MYCALEX 410 is priced comparable to mica-filled phenolics. Loss factor is only .015 1 mc., insulation resistance 10,000 megohms. Fully approved as Grade L-4B under N.M.E.S. JAN-1-10 "Insulating Materials Ceramic, Radio, Class L."

MYCALEX 410X is low in cost but insulating properties greatly exceed those of general purpose phenolics. Loss factor is only one-fourth that of phenolics (.083 at 1 mc.) but cost is comparable. Insulation resistance 10,000 megohms.



MYCALEX CORPORATION OF AMERICA

Owners of 'MYCALEX' Patents and Trade-Marks

Executive Offices: 30 ROCKEFELLER PLAZA, NEW YORK 20 — Plant & General Offices: CLIFTON, N. J.

TELEVISION ENGINEERING

Including Radio Engineering, Communications and Broadcast Engineering. Registered U. S. Patent Office.
Research . . . Design . . . Production . . . Instrumentation . . . Operation

VOLUME 3

APRIL, 1952

NUMBER 4

TVE-grams	4
Ultrahigh Tuner, Converter and Receiver Research and Design..... <i>Ralph G. Peters</i>	6
<i>Report on Analyses Offered During UHF Symposium at IRE Convention.</i>	
Magnetic Sound and Negative Picture Transmission..... <i>Robert Conner</i>	10
<i>Recently Evolved Technique Features Use of 35-MM Negative Film and 16-MM Magnetic Film Recorder.</i>	
Ceramics for Capacitors..... <i>Abraham J. Dranetz</i>	12
<i>Physical and Electrical Characteristics of Barium Titanite Ceramics and Methods Developed for Application in Capacitors.</i>	
The Telescribe..... <i>George A. Gilbert</i>	14
<i>Flying-Spot Scanning Device, Employing Scanning by Reflection. Can Be Used for Closed Circuits, Air-Traffic Control Systems, etc.</i>	
Merchandising Education Via TV.....	21
<i>Pay-As-You-Earn Plan Features Scrambled Video or Audio.</i>	

MONTHLY FEATURES

Viewpoints..... <i>Lewis Winner</i>	3
TVE-grams.....	4
Personals.....	5
Production Aids.....	24
TV Parts and Accessory Review.....	25
Instrument News.....	27
Broadcast News.....	27
Advertising Index.....	30
Briefly Speaking.....	30
Industry Literature.....	31

Cover Illustration

At UHF symposium in Washington, during which components, accessories and tubes for 1 and 10-kw transmitters were surveyed by RCA specialists, left to right: John E. Young, George Brown, Charles B. Jolliffe and T. A. Smith.

Editor: LEWIS WINNER



Published monthly by Bryan Davis Publishing Co., Inc., 52 Vanderbilt Avenue, New York 17, N. Y. Telephone: MURray Hill 4-0170.

Bryan S. Davis, President. Paul S. Weil, Vice-Pres.-Gen. Mgr. Lewis Winner, Editorial Director. F. Walen, Secretary. A. Goebel, Circulation Manager.

Mid-West Representative: Stuart J. Osten, 333 N. Michigan Ave., Chicago 1, Illinois. Tel.: DEarborn 2-3507.
 East-Central Representative: James C. Munn, 2253 Delaware Drive, Cleveland 6, Ohio. Tel.: ERievew 1-1726.
 Pacific Coast Representative: Brand & Brand, 1052 West 6th Street, Los Angeles 14, Cal. Tel.: Michigan 1732.
 Suite 1204, Russ Building, San Francisco 4, Cal. Tel.: SUTter 1-2251.

Reentered as second-class matter February 7, 1950 at the Post Office at New York, N. Y., under the act of March 3 1879. Subscription Price: \$3.00 per year in the United States of America and Canada; 50c per copy. \$4.00 per year in foreign countries; 60c per copy.

Te Aro Book Depot: Wellington, New Zealand. McGill's Agency: Melbourne, Australia.

TELEVISION ENGINEERING is indexed in the Engineering Index.
 Entire Contents Copyright 1952, Bryan Davis Publishing Co., Inc.



Serving the four key members of the TV engineering family: UHF-TV, VHF-TV, Industrial-TV and Radar.

An Announcement from

MILTON B. SLEEPER

EFFECTIVE next month, TV ENGINEERING will be combined with RADIO COMMUNICATION Magazine, which is published by Radiocom, Inc., at Great Barrington, Massachusetts.

Subsequently, it is planned that they will be published separately again. For the present, however, we believe that we can serve both readers and advertisers to best advantage by combining them in a single magazine.

Thus, starting next month, subscribers to TV ENGINEERING will receive RADIO COMMUNICATION. Behind this arrangement is a long-standing friendship with Bryan Davis and Lew Winner. My association with Bryan dates back to the days of RADIO ENGINEERING, which I founded in 1921. He took over that magazine in 1928, when I went back into radio manufacturing. Now, with the purchase of TV ENGINEERING, the rights to the RADIO ENGINEERING name, dating back 31 years, return to me.

Our staff at RADIO COMMUNICATION, headed by Roy Allison as Editor, is looking forward with great enthusiasm to the privilege of serving TV ENGINEERING subscribers. Until now, TVE has been limited in its editorial scope because it was forced to mark time during a period which was to last only six months, but actually continued nearly four years.

Now, those limitations have been removed. The freeze has been lifted, and the FCC is ready to implement the expansion of television by authorizing some 2,000 new stations.

This is a momentous period in the history of our industry. In taking over TV ENGINEERING at this time, we realize that we are tackling a difficult editorial job. Quite frankly, we admit that we do not know all the answers.

We are most anxious to know your views as to the kind of articles you want, and the angle of editorial approach you feel will be most use-

ful. We would like to have letters that represent the thinking of the broadcast engineers, of those engaged in the design of transmitters, studio equipment, and receivers, and of the servicemen whose particular concern will be the successful performance of the new UHF sets. We'd like to hear from sales and advertising managers, too, for they have constructive ideas to contribute.

You can be sure that your letters will have the most thoughtful consideration, and that each one will be brought up for discussion at our editorial conferences.

We are prepared to pay generously for articles, according to the value of the material to our readers, and the manner of presentation. Clear, sharp photographs are important. Pencil diagrams and charts, or blueprints are adequate, as all illustrations are redrawn to maintain uniform style.

By the time this announcement is in print, our Readers' Service Department will be set up. This will function as a clearing-house for information on FCC authorizations and channel assignments, and on all technical matters pertaining to TV equipment and components. You can expect us to answer your questions directly, or to tell you where the information can be found.

In short, our purpose in taking over TV ENGINEERING is not to sit back and ride the tide of television expansion, but to provide an active, constructive service as our contribution to the nation-wide growth of television.

Sincerely,

MILTON B. SLEEPER, *Publisher*

RADIO COMMUNICATION
and TV ENGINEERING
Great Barrington, Mass.

April 15, 1952

TELEVISION ENGINEERING

LEWIS WINNER, Editor

April, 1952

The Rising Demand for Engineers—With civilian, and particularly military-production schedules reaching all-time highs across the country, the need for engineers and skilled technicians, too, has become more urgent than ever.

Specifically, according to NPA officials, industry requires more than 1500 qualified senior engineers, as well as additional process engineers, testers and quality-control workers. Industry representatives have even indicated that draftsmen and technical writers are on the help-wanted list. The shortage of executive technical personnel who could serve as departmental managers and group leaders in research and development has been cited as an especially acute problem.

While a lack of educational facilities and incentives to study engineering have been generally described as the basic causes for the present emergency, many have declared that management has been guilty, too. For they have not initiated programs which could provide the necessary engineering leadership. A few in industry have been extremely active, and the results have been striking.

Reviewing the personnel and training job that faces engineering management, G. N. Thayer of Bell Labs said recently, during an IRE symposium discussion, that leadership training demands careful study. There are many factors to consider: technical competence, stability, high intelligence, genuine liking for people, intellectual honesty and courage, and good judgment. One who can direct others, it was said, should display originality, a sense of responsibility, and an ability to express ideas.

Human relations were also cited as an extremely important item in any leadership program. In the words of Thayer, human relations can be considered as the sum . . . "of all the complex relationships between all the people in the organization, including all levels of management." Relations can be good, it was said, when mutual respect, confidence, understanding and friendliness prevail throughout the organization. To achieve such relations, one must understand human nature, and be familiar with human conduct. Thayer noted that a man needs a sense of dignity, a sense that as an individual he is important, and others recognize it; he must also have a sense of security, and a sense of belonging to a group. Since a large part of one's existence is spent on the job, it is important that this social awareness obtains, and is recognized.

With the video arts now firmly established as one of the giants in American industry, there has appeared a pressing demand for those who can direct far-flung programs to assure a continuance of industry dominance; a leadership that would also undoubtedly prove inspirational to many and prompt them to enter the professional radio and TV engineering world.

Color System Progress—When early last year it was decided to reinstate the National Television Systems Committee, and begin a study of several system problems, particularly those concerning color, it was hoped that it might be possible to arrive at key solutions, perhaps in the first few months of '52, and offer such conclusions to the Commission. Unfortunately, a variety of unpredictable problems arose, and prevented adherence to the target date. As a result, many have begun to heap criticism on the committee, declaring that it would never find an answer to color, and indicating, too, that the committee's work was too theoretical and on a level which would never lead to a practical plan. It is true that there have been delays, and there will be many more, but none of these stoppages have been or will ever be due to improper direction, impractical assumptions, or feeble thinking. Rather, there has been a dominate desire to evolve a system whose reliability and proficiency could never be disputed, either in industry or by government; truly a striking goal, set by the committee. And only painstaking, time-consuming studies and probes can insure complete success to achieve that goal.

The exhaustive field tests, recently undertaken, accent the determination of everyone to find practical answers. In a half-dozen areas committee members are now evaluating such facts as flicker problems, highlight brightness, contrast, room illumination, registration, color breakup and fidelity, picture texture, adequacy of sync, color sync, sound quality, continuity of motion and color fringing with live cameras, as well as susceptibility to noise, of either the impulse, random or the *rf* interference type. A broad assortment of receivers are being used in these tests, and careful measurements are being made by representative bodies of experts.

Much time has passed since the color talks began, but substantial progress has been made, and soon NTSC will have the flawless, foolproof system for presentation to the American public.

Au Revoir—Effective with the May issue, TELEVISION ENGINEERING will no longer be published from this office; it will be included within the communications journal published by Milton B. Sleeper and his able staff.

It has been a privilege to have been able to visit with you every month for so many years. To our advertisers and those who wrote for us, we are indeed grateful for their loyalty and valued contributions—a view that it is certain is shared by all TVE subscribers.

We know that Milton Sleeper will continue to serve you in his customary capable manner.

Good sailing, Milton; and to you friendly readers, au revoir.—L. W.

Klystron-UHF Possibilities Hailed at Symposium:

The radar-born klystron, which Californians in San Bruno and San Carlos have found to be unusually effective on the ultrahighs, received an enthusiastic appraisal from a transmitter producer at a *uhf* TV symposium conducted during the recent NARTB convention in Chicago. This tube, according to H. G. Towlson of G.E., has been found to be entirely practical and reliable for high-power upstairs-TV transmission. Their model, he said, is a three-cavity amplifier with the cavities an integral part of the tube; the integral cavity design serving to keep insulation material out of the interior field (insulation would become a limitation to higher power). It was reported that the power gain of the tube was about 400 at a bandwidth of 6 mc. Towlson also revealed that since the output of the klystron varies with the input as a first order Bessel function, the degree of linearity is excellent over the operating range. Measurements were made to determine the effects of *incidental frequency modulation* of the visual carrier, since this will be an important consideration with the intercarrier type of receivers used at the higher frequencies, where buzz may occur in the audio output. With the klystron, no measurable increase in *ifm* out of the exciter was obtained.

Reviewing the construction of the tube, Towlson explained that it was sturdily constructed for long life. A bombarded tantalum-cathode is outside of the *rf* portions of the tube, permitting large emitting surfaces which can operate at relatively low temperature. To accommodate the expected ceiling of 200-kw erp, transmitters using this tube have been designed to permit a 12-kw output. In anticipation of the still higher powers that might prevail, perhaps up to one megawatt, engineers have begun to plan the construction of a 50-kw klystron. It was said that the basic design of that type of tube is entirely feasible.

Shock and Vibration-Resistant Tubes Developed:

Thirty tubes, which are from two to ten times more resistant to shock and vibration, and have twenty times the life expectancy of former types, have been produced under a Navy Bureau of Ships project in cooperation with the Army and Air Force. An announcement on the development, from the Navy, revealed that the tubes have been subjected to tests that would cause immediate failure in most present-day models. Some of the tests included a 48-hour mortality check, as well as a high-

voltage heater-cycle test, during which they were turned on and off 2000 times. In addition, the tubes received a thermal shock, comparable to the reaction obtained in dropping a cold glass into boiling water.

The new tubes are expensive, costing from five to ten times as much as the present commercial types, but because of their reliability and anticipated low replacement rate, the actual total cost will be reduced substantially. It was also pointed out that the long life of the tubes, which will reduce replacements, will also eventually reduce the number of tubes required, and thus effect economies in critical material requirements.

The commercial stock numbers of the thirty new tubes are: 5670, 5654, 5727, 5Y3WGT, 5726, 5725, 6005, 5750, 6C4W, 5933, 5639, 5899, 5718, 5977, 6111, 5641, 5647, 5896, 6110, 5643, 5644, 5749, 5751, 5814, 5636, 5840, 5902, 5719, 6021, and 6112.

Selenium Supply Outlook for '52: Little improvement in the supply of selenium can be expected during '52, members of the Selenium Producers Industry Advisory committee told NPA recently because there is little possibility of any increase in copper production; selenium is a byproduct of electrolytic copper refining, and its production is largely dependent upon the production of copper. There is sufficient processing capacity available for the handling of all selenium coming from copper refining, and the production of all grades of finished selenium (high priority, commercial and ferro) could be increased. Questioned about the feasibility of obtaining selenium from the refining of lead and zinc, the industry committee members indicated that while such ores do contain selenium, they could not be considered as a reliable source at the present time. In a subsequent inquiry covering the uses of selenium, the experts said that it was primarily employed in the colorizing and decolorizing of glass, and implied that radio and TV were minor items in the application book. This blunt view, it was felt, should be extremely beneficial to the sight and sound industry, who could request increased diversion of the precious metal. Such diversion, which would actually aid the military, permitting an increased production of rectifiers and a subsequent increased allotment of these rectifiers for civilian equipment, would in turn ease tube requirements and release production facilities for the manufacture of urgently needed tubes.



Left: Demonstrating a step in the manufacture of tubular ceramic capacitors at the recent IRE show in New York City. Hot-molding process applies 1000 pounds per unit at 300° F to an alkyd resin, forming a hard protective jacket around each capacitor. (Courtesy Speer Carbon Co.)

Below: BBC Maida Vale studio one, featuring new acoustical treatment recently applied to walls above and below balcony to improve the reverberation and frequency response of the studio.



New Posts: *J. H. DuBois*, formerly sales manager of the Plax Corp., a division of the Emhart Manufacturing Co., has been appointed a vice president in charge of engineering of the Mycalex Corp. of America. . . . *Harry C. Nelson* has been appointed manager of instrument sales of Polytechnic Research and Development Co., Inc. *Herbert A. Finke* has been named director of engineering. *Harmon R. Traver* is now manager of manufacturing and *W. A. Yearsley* has become western sales engineer of the recently opened western sales office. . . . *Harry Bittan* and Co. have been named reps in metropolitan New York for Crest Laboratories, Inc. . . . *Fred Miller*, formerly chief engineer for Kaye-Halbert, has been named director of engineering for the firm. . . . *I. L. Brandt*, formerly project engineer for the Continental Electric Co., has been appointed chief engineer of Taylor Tubes, Inc. . . . *Edward L. Beaudry, Jr.*, formerly president of Kay Electric Co., is now president of Chase Resistors Co. . . . *Louis H. Niemann* has been appointed eastern sales manager of Hytron Radio and Electronics Co., succeeding *Fred Garcelon* who has been named assistant to John Q. Adams, vice prexy in charge of sales. . . . *Art Cerf* has been appointed rep for the Bridgeport Brass Co. in New England and east-central states.

At the IRE National Convention: *Frank Lyman*, president; *M. G. McGillen*, vice president; and *Dan Comins*, chief engineer (Cambridge Thermionic Corp.) . . . *Miryam Simpson*, s-m; *Len Werner*, chief engineer; *David Libshon*, asst. s-m; *Henry Berlin*, sales engineer; *Philip Optner*, director of purchasing; and *Bill Wolfner*, design engineer, (Masco Sound Systems.) . . . *Leonard Carduner*, president; *Franklin Hoffman* and *Morton Lee*, engineers (British Industries Corp.) . . . *H. Cohen*, vice president; *Julian Loebenstein*, s-m; *J. Kabgan*, sales rep. (Radio Receptor). . . . *J. L. Roemisch*, president and chief engineer; *D. L. Schacher*, asst. chief engineer; *L. P. Blakely*, s-m; *H. J. Titus*, design engineer; *M. Star*, *J. Rabinowitz* and *C. L. Fruchter*, development engineers (Tel-Instrument Co.) . . . *Milton Gussack*, *Seymour Gussack*, *William Hehayias*, *Fred Breinlinger*, engineers; and *N. A. Gussak*, general manager (Grant Pulley and Hardware Co.) . . . *S. E. Warner*, director of engineering; *L. F. B. Carini*, assistant chief engineer; *J. E. Respass*, president; *Fred Hess*, s-m; *M. V. Fields*, general s-m; *Laurence Kearney*, field engineer (Vec-D-X). . . . *M. P. Fieldman*, general s-m (Halldorson). . . . *B. F. Linck*, sales promotion manager, Elastic Stop Nut Corp., t.

J. H. DuBois



Edw. L. Beaudry, Jr.



Art Cerf



J. H. Painter



Glen Ramsey has been named general manager of the rectifier-capacitor division of Fansteel Metallurgical Corp. . . . *Harold L. Herndon* is now district manager in charge of sales and service for the Cleveland district of the Raytheon Manufacturing Co. *Albert R. Wolfe* has been named service manager. . . . *Stanley Wolff* has been appointed director of sales engineering for Stelma, Inc. . . . *Ernest A. Marx* has been named director of the international division of Allen B. DuMont Labs. . . . *Russell J. Tinkham* has been appointed manager of the Chicago office of Ampex Electric Corp. . . . *Dr. Allen B. DuMont* has been named a member of the Industrial Council recently organized at Rensselaer Polytechnic Institute. . . . *Lewis E. Pett* has been appointed western district manager for the television transmitter division of DuMont. . . . *John H. Painter* has become a special rep for G.E. broadcast equipment, with headquarters in the Wyatt Bldg., Washington, D. C. . . . *Wells R. Chapin* has joined the G.E. electronics division as a district sales manager for radio and TV broadcasting equipment. . . . *John J. Radigan, Jr.*, has been appointed vice president in charge of industrial relations of P. R. Mallory and Co., Inc. . . . *George E. McAllister* has been appointed division manager of the Norwood plant of Workshop Associates. . . . *E. J. Baughman* is now GPL west coast rep.

Don Nichols, sales service manager; *Wilbur Grant*, assistant s-m; *James A. Pettit, Jr.*, engineer (Plastoid). . . . *R. P. Scott*, sales engineer and *W. A. Nicely*, v-p. sales (Chicago Telephone Supply). . . . *G. Geopfert*, plant manager and *Hugh Veley*, chief engineer of research and development. (Speer Resistor Corp.). . . . *William Fehrenback*, plant manager; *Harold Higgs*, chief electronics engineer and *Harry Waddell*, assistant s-m (Jeffers Electronics, Inc.). . . . *H. L. King*, general manager; *J. G. Twist*, s-m; and *K. McGee*, chief engineer, (Sangamo). . . . *A. J. Schmitt*, president; *R. M. Purington*, vice president in charge of engineering; *W. H. Rous*, vice president in charge of sales; *R. M. Krueger*, sales engineer; *K. Klostermann*, chief engineer; and *K. F. Boldt*, advertising manager. (Amphenol). . . . *C. A. Bradford*, G.E. tube division manager sales promotion; *E. H. Fritschel*, manager sales of industrial and transmitting tubes; *J. H. Sweeney*, manager of germanium diode sales; and *R. H. Randolph*, test equipment s-m. . . . *D. J. Harrington*, G.E. capacitor division s-m. . . . *C. W. Creaser*, s-m; *G. G. Greene*, vice president; *W. L. Page*, production coordinator; and *I. J. Metcalfe*, engineer. (Workshop Associates Div., Gabriel Co.). . . . *Ken Shaeffer*, Mallory vibrator division manager; *G. Peck*, Mallory capacitor division manager; and *T. Harries*, s-m Mallory TV tuners.

W. R. Chapin



E. J. Baughman



G. L. McAllister



Harold L. Herndon



ULTRAHIGH Tuner,



AT THE UHF SYMPOSIUM, during the IRE meeting, left to right: E. Hylas and W. V. Tyminski (DuMont), R. A. Varone (Admiral), James White (Zenith Radio), H. A. Chalberg (G.E.), T. Murakami (RCA), ye editor who served as moderator, D. D. Israel (Emerson Radio), E. D. Johnson (RCA), W. B. Whalley (Sylvania), A. M. Scandurra (Kollsman Instrument Division of Standard Coil), M. F. Melvin (Mallory), John Bell and Max Beier (Zenith Radio).

THE ULTRAHIGH, no longer dismissed as an airy dreamland, but rather accepted as an extremely practical home for telecasters, has begun to receive priority attention in numerous labs of receiver, tube, transmitter and accessory manufacturers. And the results have been intriguing, with an assortment of tuners, converters, antennas, tubes and crystals, and amplifiers appearing on the scene.

The tuner-converter front has been particularly active, with a host of solutions posed. Some have indicated that the answer to reliable *uhf* lies in the turret tuner. Others have announced that it's the tuned transmission line which can provide the best performance, and still others have favored the variable inductance idea.

At the recent IRE national convention in New York City, the first detailed appraisal of the foregoing techniques was offered during symposia

sponsored by the professional group on broadcast receivers.

Turret Tuners

Supporting the turret-tuner method, John Bell of Zenith declared that experience has shown that there has been a public preference for the snap type of tuning which permits the user to go from channel to channel in a single operation. This, it was said, has been provided by the turret type of tuner in which channel strips on a turret are moved past the indexing point. The strips are replaceable and can be made interchangeable in a given type of turret.

The tuner providing *vhf-uhf* coverage, was described as featuring two-section design, a solid partition extending over the entire cross section of the tuner housing. The shield, together with proper placement of parts and circuits, was claimed to permit more than ade-

quate isolation of the oscillator from the antenna.

Analyzing the basic elements of the tuner, Bell said that a 6BK7 double triode is used in a cascode *rf* amplifier, a single-tuned circuit on the first grid of the cascode providing some preselection between the antenna and *rf* amplifier. A double-tuned circuit is used between the output of the cascode and the converter grid of a 6U8, a new triode pentode. It was noted that a pentode converter is preferred, because a triode would have to be accurately neutralized when used as an amplifier on *uhf*.

To cover the entire *uhf* band, the *vhf* oscillator must tune between 172 and 234 mc. Thus, it was said, the third harmonic of the oscillator is used on the low *uhf* frequencies and the fourth harmonic is used on the high *uhf* frequencies. The desired harmonic output of a multiplier crystal is used to

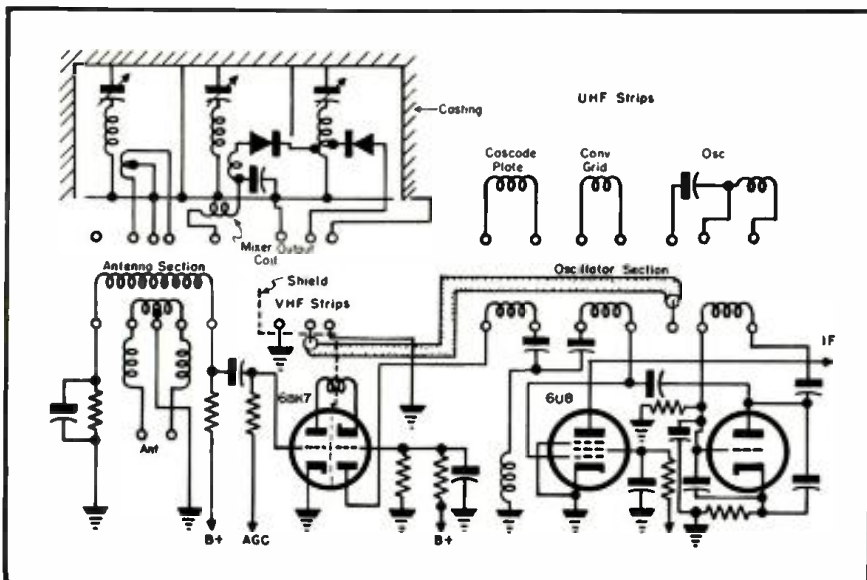

(Left)

SIMPLIFIED CIRCUITRY of vhf-uhf tuner, described by Zenith Radio engineers.

(Below)

BLOCK DIAGRAM of receiving system with uhf strips in place, analyzed by Zenith experts.

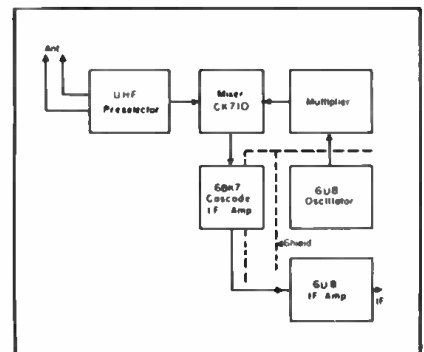

Converter and Receiver

Research and Design

by RALPH G. PETERS

A Report on Analyses Offered During UHF Symposium at IRE National Convention by M. F. Melvin (Mallory), H. F. Rieth (Kingston Products), John Bell (Zenith Radio) and A. M. Scandurra (Standard Coil).

excite a germanium mixer crystal, which is preceded by two preselector tuned circuits. The design thus provides three *uhf* tuned circuits and two germanium crystal diodes mounted in a die-cast housing, designed to replace electrically and mechanically the antenna section of the *uhf* channel strip.

Reviewing the objective of the 6BK7 cascade, Bell declared that it was selected to obtain the lowest possible noise figure on all channels consistent with cost and reasonable simplicity. The cascode interstage is series tuned near channel 13 by means of a series coil connected between the first plate and second cathode. Accordingly, he pointed out, the two triodes are thus connected directly in series and, therefore, have identical plate currents. The grid of the second triode is held at a fixed potential by means of a voltage divider between B+ and ground, giving a relatively rapid cutoff in the first triode, which is controlled by the *agc*

voltage. So that the gain of the cascode may not be reduced before the signal is completely free of noise, Bell said, a delayed action is provided in the application of *agc* to the 6BK7. This is accomplished by providing some cathode bias on the *if* amplifier and allowing the *agc* voltage to go positive by this amount. When the *agc* voltage is positive, it was shown, a 2.2-megohm grid leak on the 6BK7 holds its grid near zero; actually slightly negative due to contact potential. When the *agc* voltage passes through zero the signal level was described as high enough so that the noise figure of the *rf* amplifier is no longer important and the 6BK7 is then cut off rapidly by a further increase of *agc* voltage in the negative direction.

Describing the *uhf* tuned circuits, Bell said that they are mounted in a cylindrical hole .205" in diameter and

†Rexolite.

$\frac{1}{2}$ " deep. The coils themselves are .4" long and $\frac{1}{8}$ " in diameter. Tuning capacity is provided by the proximity of the top end of the coil to a No. 1-72 machine screw which enters the coil through a No. 1422 mounting bushing‡. No other connection was said to be necessary to the top end of the coil. It was noted that substantial tuning ranges can be achieved with very small capacities by this method because the minimum capacity of the circuit is not increased by connections to a variable capacitor and the parts of the capacitor etc. The minimum capacity of the circuit was said to be approximately $\frac{1}{4}$ mmfd; thus the *uhf* range can be covered with three different coils. There are three different housings to cover the *uhf* band; the first covers from 470 to 602 mc, a second from 608 to 734 mc, and a third from 740 to 890 mc.

The mixer output circuit was described as a simple pi network in which

THREE-SECTION *uhf* variable-inductance tuning system tuner reviewed by Melvin of Mallory.

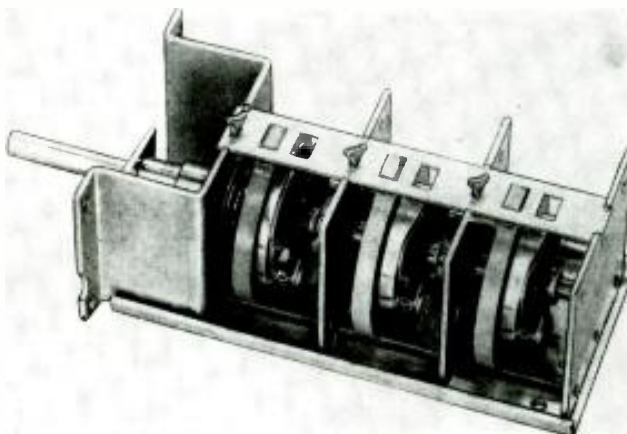

STRUCTURE OF OSCILLATOR tuning and mixer-tuning elements in Mallory unit.

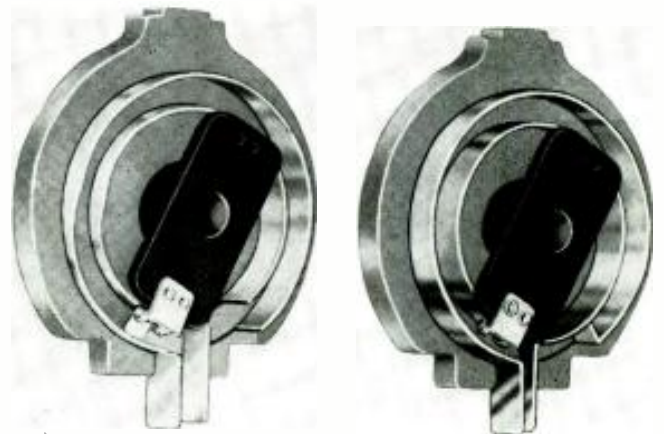

the *rf* bypass capacitor is the input capacity, and the grid-cathode capacity, or the input capacity, of the 6BK7 is the output capacitor. This simple network was said to provide very nearly optimum coupling between the crystal and the grid of the 6BK7 for best noise figure. The bandwidth of the input circuit is determined entirely by the damping provided by the mixer crystal. In this way, it was noted, the mismatch between the crystal and the first grid is nearly complete, with the result that there is realized most of the 3-db improvement in noise figure which is available if the *if* amplifier absorbs no power from the crystal.

Reviewing the operation of the *uhf* channel strip, Bell said that the cascode plate and the converter grid are tuned to *if* and the coupling between them is adjusted for proper bandwidth to give full response at both the sound and picture carriers. Capacitor coupling between the oscillator coil and an extra turret contact (No. 11) feeds excitation through a coax cable to the multiplier crystal in the antenna section. This contact in the antenna section is shielded as completely as possible by two grounding strips on either side of the contact and by the arrangement of the shield which permits a minimum amount of the contact to be exposed to the antenna compartment; thus, it was noted electrostatic capacity coupling is reduced between this contact and the antenna coils. The antenna coils are arranged with the ground contact between the antenna primary and the *rf* grid contact. Thus, the two antenna contacts are adjacent to each other, reducing the loop area of the antenna leads which can couple magnetically to the oscillator through the multiplier contact which carries oscillator current to the multiplier crystal. This was said to be important when the *uhf* channel strips are in place, serving to reduce oscillator radiation. This arrangement also permits additional isolation of the antenna contacts from the *rf* grid reducing direct *if* pickup on *uhf*.

Detailing the performance of the system on *uhf*, Bell noted that the noise figures on channels 24 and 47 (535 and 670 mc) were 14, and 17 on channel 72 (820 mc). Image rejection on channels 24 and 47 was said to be 50, and 45 on channel 72. The *if* rejection on channels 24 and 47 was noted as being 60 and 59, and 58 on channel 72. Relative gains for channels 24, 47 and 72 were said to be .81, .72 and .65.

82-Channel Turret Tuner

In another dissertation on turret tuners, Aldo Scandurra of Kollsman

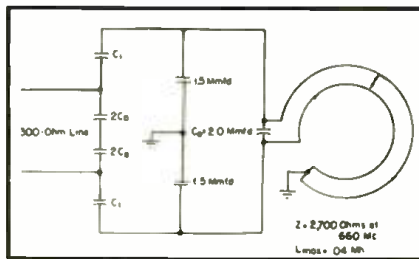

ANTENNA-COUPLING arrangement in variable inductance system.

Instrument[‡] reported that there had been developed a combination veryhigh—ultrahigh tuner, in which channel selection was accomplished through a scheme of dual conversion, the *uhf* band being divided into eight parts. The *uhf* channels are converted to *vhf* and the *vhf* section of the tuner is used as variable first *if*. This approach was said to provide a decimal system of counting for tuning of the *uhf* channels. Resonant circuits for the arrangement were noted as being obtained through the use of lumped parameters; tuning of the *uhf* oscillator and *uhf* mixer is accomplished by switching these lumped parameters across fundamental circuits.

Band Circuitry

For each of the bands, Scandurra said, the tuner consists of a *uhf* preselector, a *uhf* mixer and oscillator, and a first *if* system of the cascode type. The *rf* switch serves to separate the antenna feeds. In the *uhf* position, the antenna is fed to preselectors and the output of the *uhf* mixer excites the *vhf* first *if*. In the *vhf* position, it was noted, the antenna terminal is connected to the input of the *vhf* tuner; in

[‡]Subsidiary of Standard Coil Products Co., Inc.

The 82-channel turret tuner described by Scandurra of Standard Coil.



this position, the *uhf* section of the tuner is inactive.

In this arrangement, when a particular tens digit is selected, actually there is selected one of eight *uhf* bands with its associated preselector and oscillator setting. When a units digit is selected one of the variable intermediate frequencies is chosen. Due to the numbering of the *vhf* stations, the dial presentations are arranged so that the *uhf* numbers appear in the upper portion of the window, and *vhf* numbers in the lower portion.

Method of Tuning

Reviewing oscillator systems studied for the system, the Kollsman specialist pointed out that an 800-mc oscillator consisted of two coils in parallel connected across the tube socket, in this particular case, pins 1 and 2, and 6 and 7. The *dc* isolation between the grid and plate was effected through a small gimmick wound around the end of each coil. This provided a small capacitance connecting the tube to the circuit. Filament chokes used had about 20 turns of No. 28 SSE closely wound on a 1/8" form. Based on these simple experiments, the work was carried on to extend the use of lumped parameters.

An oscillator was built, using a sub-miniature type tube which operated in the neighborhood of 1250 mc. The inductances consisted of two coils in parallel, with two turns of No. 24 wire wound on a 3/16" form, connected to the tube element through a gimmick capacitance of approximately 1 mmfd. The method of incremental tuning by paralleling lumped inductance and capacitance was found to be ideal for a turret tuner. The *Qs* of the circuits were found to be high, of the order of 100 or greater. If the fixed coil is stabilized for possible temperature variations, the deviation in switching from one channel to another can be held to a minimum.

Design of Oscillator

In evolving an oscillator design, the choice of a tube loomed as a key factor, it was noted. The choice was said to be complicated not by the lack of a suitable tube, but by the variety available. With lumped circuits, at least six different types of triodes were embodied in oscillator circuits. All were found to perform satisfactory. Most of the work was conducted with the 2367A^a and 1165E^b tubes. In the course of experimentation, oscillators were assembled using other tube types such as the 6BK7, 6BZ7, 5703, 6K4, 6J6, etc.; all have been found to operate rather well in the *uhf* range.

In experimenting with the oscillator,

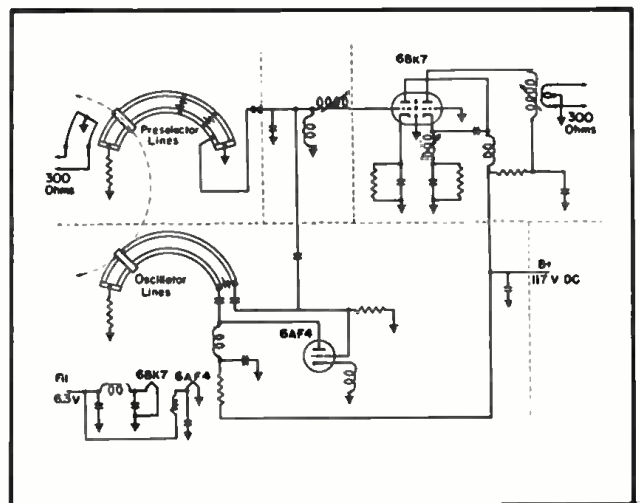
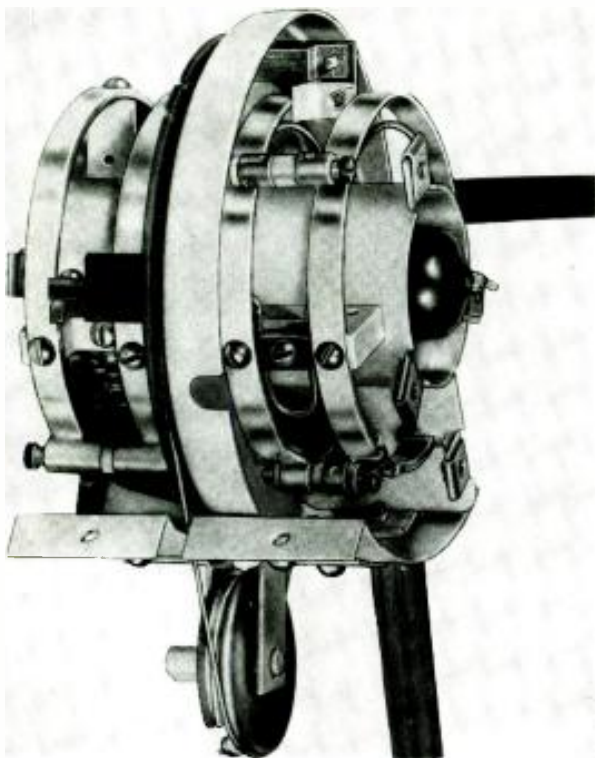

(Above)

Schematic of tuned-line tuner analyzed by Rieth of Kingston Products. (See p. 29 for system analysis.)

(Left)

Top view of Kingston Products tuner, with shields removed. Shown are the preselector lines and the slider with their respective trimmers in place. Back of the line is the antenna coupling loop. Also shown is a portion of the cascode if amplifier tube.

it was established that the resonance in the filament cathode circuit could be troublesome. Continuous tuned oscillators were assembled which required no change in the cathode circuit. However, those oscillators were found to be critical in adjustment. The use of a switched *uhf* oscillator served to reduce this effect, enabling the optimizing of the plate current through the frequency range. The maximum plate current in the final oscillator on any of the channels was on the average less than 20 ma for 80 v anode voltage on a number of tubes which were available.

Tests showed that once the fundamental circuit was established at the center of the range, the other oscillator frequencies could be obtained rather easily by adjustment of the increments. The possible variation with the trimmer was found to be approximately ± 7 mc.

Design of Preselector

The present tuner was described as using double-tuned circuits with coils as increments for all of the eighty bands. A broadband response was achieved by proper positioning of the antenna output and the mixer input, with no resistive loading used. This setup was said to result in an optimum transfer of power with the only dissipation existing in the radiation losses and the loss within the coils and capacitors associated with the circuit. The noise factors which were measured in the

*RCA. ^bSylvania.

lab indicated that the loss in the preselector varied from 1 to 2 db.

In the present model, a capacitance of the order of $\frac{3}{4}$ mmfd is included as a variable capacitor to adjust the circuit in the 870 to 890-mc range, in addition to the incremental inductance from the turret. This was said to set the fixed circuit, and no other adjustments need be made for the remaining seven bands. The fundamental circuit operates in the neighborhood of 400 mc when incremental inductances are used. Scandurra noted that this lower frequency of operation of the fixed circuit was chosen to obtain incremental inductances which were small in size. For this purpose, a circuit operating at 400 mc or below was found to be better than a fixed circuit operating at higher frequency, since the size of the incremental inductances for the various channels has been kept reasonably small. It was noted that one could use a circuit operating in the neighborhood of 600 mc and use capacitances and inductances for achieving the required responses. However, the use of capacitors has been found to be limited to the bandwidth requirements, while inductances have resulted in a more efficient transfer of energy.

Variable Inductance Tuners

In a paper covering the possibilities of variable inductance systems for *uhf* tuners, H. F. Melvin of Mallory disclosed that two types of tuners have

been designed for this service. One has been a so-called dual-line tuner.

The tuner was said to be a compact assembly of variable inductance available in one, two, three, or four sections in the same case.

In this unit, dual inductor elements, arranged in a non-inductive, concentric path, provide an inductance range in 270° of rotation (less than a single turn).

Preselector tuning elements are shaped differently from each other and from the oscillator tuning elements (available for various *if* frequencies, at, roughly, 40, 80, and 130 mc) to provide good tracking when used in converters and front-ends. The maximum deviation in resetability from one production element to another was said to be less $\pm 0.8^\circ$ at 130° rotation (approximately ± 2 mc at 660 mc), where the maximum error occurs. The *rf* range of the preselector was described as being approximately 1.98 (460 to 910 mc) in 270° of rotation.

In a review of the antenna section it was said that two small arcs of silver ribbon (approximately 70° long) were imbedded on the back side of a coupling element. These are concentric with the tuning element, and in a position to provide approximately balanced capacitive coupling to opposite ends of the variable inductance.

Analyzing a converter that has also been developed for *uhf* coverage, Melvin said that the converter is divided

(Continued on page 20)

MAGNETIC SOUND and

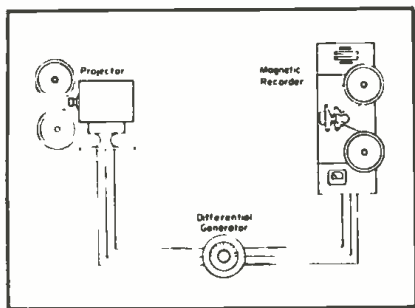

(Above)

HOOKUP of projector, magnetic recorder and differential generator.



(Above)

KLAC-TV FILM SUPERVISOR Walter S. Getze operating the differential generator control to either add or subtract frames in interlock system.

Cinemascope Recording Technique Developed at Hollywood TV Station Features Use of 35-Mm Negative Film, Which Is Easier to Process and Provides Better Resolution, and 16-Mm Magnetic Film Recorder, with Extended Frequency Response, Which Can Be Driven by Both Sync Motor and Separate Interlock Motor.

IN THE EMBRYONIC STAGES of television, the general public were not too concerned with picture and sound quality. Live television was not criticized too severely, as long as voices were understandable. As we came into the picture-tube recording era, however, there appeared criticism of bad sound and poor picture quality.

The original TV recording equipment had been designed for 35-mm film. It was quickly realized that film costs would be completely out of line with what the stations could afford in operation. Thus, 16-mm sound and picture film was adopted, irrespective of the end result. The 16-mm medium was not actually faulty in fine definition and standards required for picture quality, but there was no equipment which could be pressed into service to meet the new requirements of TV.

As talent and production costs pyramided, picture-tube recording became mandatory, even though there was sacrifice of technical quality. The assorted problems of time and differentials between the two coasts, lack of stage facilities and engineering talent accentuated the need for an immediate solution to the recording difficulty.

At our station, considerable amount

of time was spent on techniques and equipment which might be used with the two film sizes. In the summer of '49, we were asked to serve independent stations in the east with recordings of our local shows. We found that a far better than average picture could be produced by handling our picture on 35-mm negative stock. In transmission, this is electronically run through a positive-negative switch which provides a positive picture for the video transmitter.

Even though we are situated in the film capital, where probably the best film processing laboratories in the country are located, the labs found it difficult to control processing of composite reversal picture and sound film. The trouble revolved, in part, about the gamma for the picture development, found to be considerably different than for sound, although the time element required a fast processing system which meant that both picture and sound would have to be compromised in a reversal process. Adoption of a 35-mm negative picture provided the advantages of excellent intermittent motion, better resolution and far better processing. Furthermore, the elimination of the chemical reversing process or the need for contact positive prints not

‡ *Stancil-Hoffman model S5 magnetic film recorder. Specifications indicate frequency response of ± 2 db from 45 to 7,500 cycles with a signal-to-noise of over 50 db at 1% total harmonic distortion. KLAC-TV engineers found that the recorder actually bettered these minimum specifications. On actual measurement the high-frequency response was found to extend to 10,000 cycles. Further, the flutter or wow has been found to be very low: .1% flutter was measured against 0.5% on KLAC-TV standard projection equipment.*

(Left)

REAR VIEW of magnetic recorder reproducer† showing motor drive systems. The encased motor in the center is a 900-rpm sync drive motor. Directly below this is the single phase interlock motor geared to the silent drive chain. The two torque motors for the feed and takeup reels are mounted above and below the sub-chassis assembly. The differential motor is shown on the bottom panel.

(Right)

PROJECTOR with covers in place.

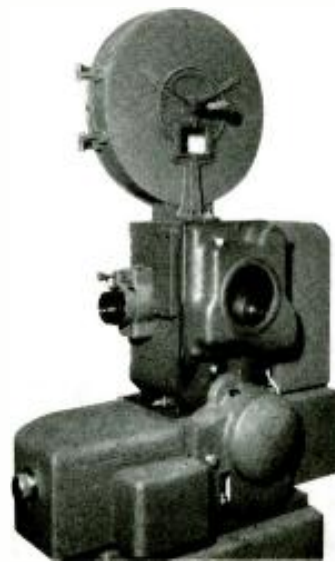

NEGATIVE PICTURE

Transmission

only saved time, but produced a far better end result. With the reproducing methods now used, it is difficult to distinguish between a live and a *cinemascope* picture. It is true our raw stock cost increased somewhat. However, since only a negative is used, this increase is a minor item.

Having surmounted the basic problems of picture quality, there still existed the problem of sound recording and reproduction. We had followed the fast advance of magnetic recording and made engineering investigations as to how we could take advantage of magnetic quality and yet keep our basic operation procedures as simplified as possible.

The immediate considerations were to adapt a medium of positive synchronization, and one that could easily be handled and edited. A single system picture-sound film would not answer our requirements, as the physical displacement between the picture and sound track prohibited close editing. We hesitated to embark upon the quarter-inch magnetic tape units using sync pulses, since it was felt that the reproducing equipment was far too critical in operation and adjustment. This led us then to make a survey of perforated magnetic film equipment which could

by **ROBERT CONNER**

Director of Engineering, KLAG-TV

be obtained to meet our requirements. Since we were considering a negative picture without sound track, we had to find a magnetic recorder which could easily be electrically interlocked with our projector. Upon investigation we learned that there was available a 16-mm magnetic film recorder[‡] which exceeded the performance of most of the major picture studio 35-mm equipment. Further, it could be driven by both a sync motor and a separate interlock motor. It was felt that with extended frequency response and good motion it would be wise to use 16-mm instead of 35-mm magnetic film which would decrease both the bulk and expense of raw stock.

All control is handled by push buttons which permits extended remote control operation as desired. The audio circuits are normal 600-ohm high level input and output which ties into our audio systems.

Electrical interlock has been achieved by mounting a single phase interlock

motor on the 35-mm projector frame. The bracket and the silent chain drive between the projector motor and the interlock motor are illustrated below. Using the chain method of coupling has served to eliminate the problems of critical alignment and gearing. The magnetic film recorder is normally driven by a hysteresis synchronous motor operated at 900 rpm. To keep our interlock motors on a one-to-one basis, we gear down from 1800 to 900 rpm by means of the silent chain at the projector.

The magnetic film recorder design is unique, since it permits the easy addition of such an interlock motor, as the only gear train is a 5:1 reduction between the sync motor and the sprocket drive shafts. As illustrated, the interlock was mounted separately from the sync motor and any size or speed motor can be installed. For our 900-rpm operation a 16-tooth fibre gear was selected to drive the chain. Should we have occasion in the future to establish our interlock speed at 1440 rpm (standard shutter shaft speed) or 1200 rpm (standard distributor interlock motor speed) this can be accomplished by changing the 16-tooth drive to achieve a different gear ratio without in

(Continued on page 26)

INTERLOCK MOTOR mounting on the 35-mm projector.



SILENT CHAIN coupling of the interlock motor to the projector sync motor drive shaft.

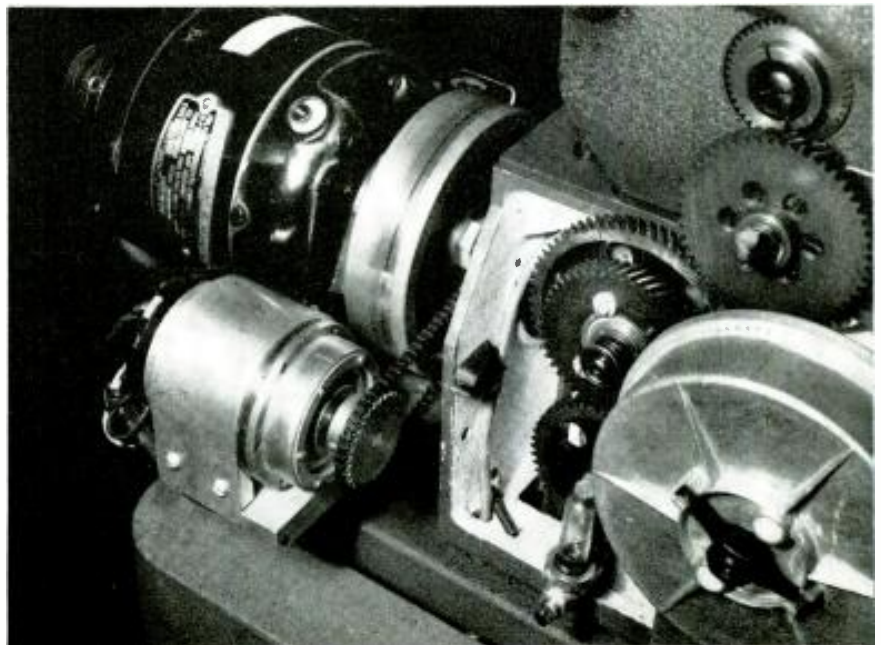

TYPICAL TEMPERATURE compensating capacitors. At left, are .03, pair of .01 and pair of .0002 types, while at right are a .05, .005, .01, .002 and .02 ceramics.

Ceramics for Capacitors*

by ABRAHAM Z. DRANETZ, Director of Engineering, Gulton Manufacturing Corp.

A Review of the Physical and Electrical Characteristics of Barium Titanate Ceramics and Methods Developed for Their Application in Capacitors

IN TV and the allied arts, it has been found increasingly necessary to use capacitors which can be depended on for temperature stability. Ceramic type capacitors have indicated that they are ideal for this purpose.

During the first World War the Germans did a great deal of work with ceramic capacitors, containing principally rutile titanium dioxide. Since then, many laboratories have engaged in extensive ceramic capacitor research, finding ways and means of producing ceramic capacitors in a large variety of characteristics and sizes.

The ceramic capacitors do have a lower breakdown strength than micas, but they have a number of advantages over the micas they are now replacing. The ceramic is not a critical material; dielectric constants are much higher by a factor of 3 to 50, and hence can be made much smaller in size; in tem-

perature cycling, the ceramics are much more reproduceable; and the ceramic bodies can be tailored for the specific use. For example, it has been found possible to produce materials with dielectric constants between 17 and 300, and temperature coefficients from +100 ppm/° C to -2,500 ppm/° C. These temperature coefficients are relatively constant from -40° C to +65° C.

Processing, during the early '40s, involved pressing of the dielectric material in the green state, after which it was fired. However, during World War II it was found possible to fabricate thin ceramic sheets.¹ This process consists of laying down a paint-like suspension onto an endless stainless steel belt, drying through several ovens,

stripping the pliable material from the belt, cutting it into standard sizes, firing it at 2,500° C, and firing on glass-bonded silver electrodes. Following this, the material is cut into desired sizes. This system can be used to produce dense (density is extremely important for good dielectric strength) dielectric sheets ranging in thickness from .003" to .030".

Capacitors that have been produced have been rated for use at 150 or 500 *wv dc*, up to 85° C. Due to electronic conductivity within the ceramic, as the temperature is increased beyond this, the resistivity drops rapidly from 8×10^{13} ohm-cm (the room temperature resistivity), and the breakdown strength suffers somewhat. As a result, it is necessary to derate the capacitors voltage-wise above 100° C.

During studies of dielectric measurements of various titanium compounds,

*From a paper presented before the Dayton section of the IRE.

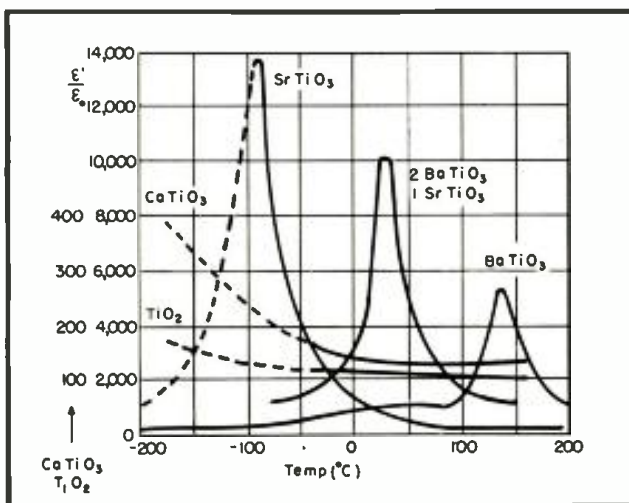

(Left)
CURVES illustrating effect of adding strontium titanate to ceramics.

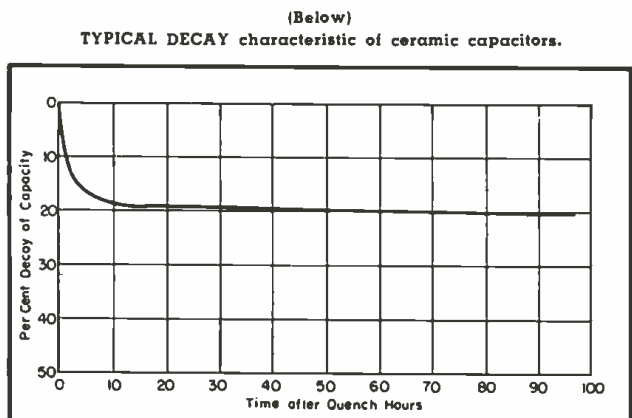

(Below)
TYPICAL DECAY characteristic of ceramic capacitors.

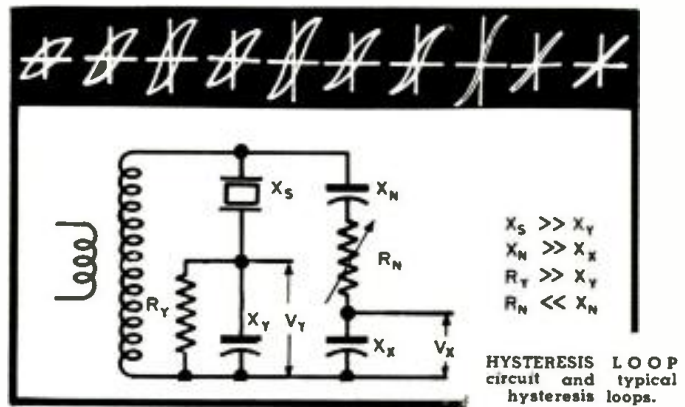
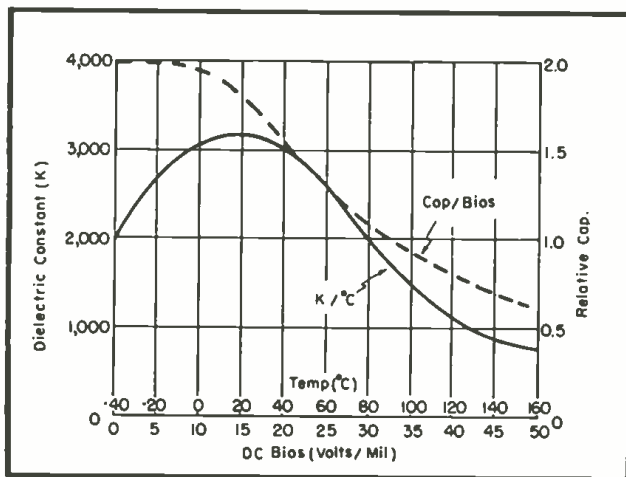

(Left)
CHARACTERISTICS of one type of ceramic (87-12) illustrating its effect as a bias control.

it was observed that barium titanate exhibits a very high dielectric constant at room temperature. This characteristic prompted many to investigate this property further and determine how it might be applied. The probe resulted in the evolution of a host of uses for commercial as well as military equipment.

It has been observed that pure barium titanate, which is a polycrystalline ceramic, has 3 Curie points, at -70 , $+10$ and $+120^\circ \text{C}$. these Curie points being temperatures at which the crystal structure changes from one type to another. The upper Curie point is characterized by a very sharp peak in the dielectric constant.

Experiments have shown that the addition of foreign agents could markedly affect the dielectric characteristics. For example, the highest Curie temperature can be lowered linearly with increasing contents of other titanates or zirconates. By lowering the upper Curie temperature to room temperature and flattening the peak by means of other materials, it is possible to obtain ceramic with an extremely high dielectric constant which is relatively flat over a limited temperature range.

Having loss tangents of approximately 2 per cent, these dielectrics are presently being used in miniature capacitors for all types of equipment. Fabricated in single or multilayer units, these materials are used in capacitors ranging from 300 to more than .1 mfd, and rated from 150 to 500 *uv dc*. Multiple capacitors have been made in single units.

One of the interesting properties of the ceramics² is their time dependence characteristic. If such a material is heated above the Curie point and then returned to room temperature, the capacitance will be found to be abnormally high, but will decay to an equilibrium value. This decay, which takes approximately two days to stabilize, requires storage of the unit for three days

before applying production tolerance tests.

These ceramics also have a charge-voltage curve which forms a hysteresis loop very similar to the magnetization induction hysteresis loop of ferromagnetics.

Since the change of charge with respect to voltage (the slope of this curve at any point corresponds to incremental capacitances with appropriate *dc* bias), one can see that by controlling the *dc* bias, the capacitance can be controlled. Furthermore, after removal of the bias, it takes several hours for the material to stabilize to the unbiased value.

The ceramics have been used in a dielectric amplifier, a modulator with detector output. In one instance, the system has featured two tuned circuits in series opposition, one controlled by ceramics, the other fixed. Application of bias to the ceramic capacitors has been found to cause a change in the resonant frequency, resulting in a modulated output, which can then be detected.

This type of circuit would make an excellent *go-no-go* circuit. Since a single *rf* source may be used for a number of stages, such units might be used in series groups to eliminate banks of tubes.

Dielectric amplifiers are essentially power rather than voltage amplifiers. A unit similar to this was found to have a power gain of 15 with a 5,000-cps input.

Piezoelectric Properties

During the course of dielectric investigations, it was observed that upon application and removal of a high dielectric field barium titanate is piezoelectric.

Briefly, not all the piezoelectric characteristics of the ceramics are better

²Developed by Howatt of Gulton, collaborating with MIT-Hi-K.

than those of other materials; taken on the whole, they are generally superior. To be more explicit; as a receiver of mechanical energy, the ceramic produces less voltage than rochelle salt, and the same order of magnitude as *adp*, quartz or tourmaline. However, rochelle salts are subject to damage by heat moisture and mechanical pressure, and are generally avoided when reliability and stability are important. Quartz, *adp* and tourmaline have extremely small dielectric constants, of the order 10, compared to the ceramics, and hence present electrical loading and shielding problems.

In addition, the availability of ceramic constituents, the ease of handling, the variety of sizes and shapes, and the general flexibility of design not possible in single crystals, added to the relatively low cost when production quantities are involved, all favor the use of ceramic wherever possible.

Sizes and Shapes

It has been found possible to mold barium titanate into tubes, plates, rods, discs and spherical shells. The material is also readily machinable. Furthermore, it has been reported that the power handling capacity is upwards of 50 watts per square centimeter.

While the ceramics have been normally prepared in the form of thin sheets, the material can be made in other ways: pressed, cast or extruded. Normally, ceramic that has been cast is a much more dense ceramic, and consequently better than pressed or extruded ware, even though the appearance is somewhat rougher. It can also be machined with diamond tools and can be made in a variety of sizes and shapes.

Flying-Spot Scanning Device, Employing Scanning by Reflection, Is Capable of Providing 1000-Line Definition and Can Be Used for Closed-Circuits, Video Mapping or Overprinting of Maps on Radar Displays, Air Traffic Control, Serving as an Instantaneous Data Transmission System, and as an Alternate for the IO for Caption Writing, Effects, Backgrounds, Etc.

The TELESCRIBE

Figure 1

ARTHUR FERRIER, British cartoonist, demonstrating at the recent British National Radio Exhibition, the Telescribe. Below, at right, appears reproduction of drawing.



by **GEORGE A. GILBERT**

Manager, Industrial Technical Department, Tube Division
Mullard, Ltd.

IN THE EARLIEST DAYS OF TV, flying light-spot scanning competed strongly, and even successfully, with image interrogation, as a means of dissecting a picture subject for sequential transmission.

In 1926, during the Baird TV demonstrations, a lensed disc interrogator was used. However, in '28 Baird employed flying light-spot scanning for a while. In so doing, he adopted a type of disc suggested by Nipkow, in a German patent as long ago as 1884.¹

The first regular transmissions by Baird employed mechanical-disc flying-spot scanning, and when in '29 the BBC took over these transmissions as a regular service, the same system was continued.

But mechanical methods, though providing reasonable light, had severe limitations, and by '31 von Ardenne² had successfully used a cathode-ray tube to scan through a film. He claimed a line frequency of 1500 at 15 frames of 100 lines, though this may have been

above the resolution of either scanning tube or gas-filled photocell.

With the advent of the iconoscope the method lapsed for many reasons: mechanical troubles with one system; inadequate light with the other; ineffectiveness in ambient light, especially daylight; effect on human subjects; unsatisfactory lighting effects owing to point of source origin, and others.

In recent years, flying-spot scanning through films, for TV film transmission, has been so developed that the method is felt to be superior to storage tube techniques using iconoscopes or orthicons.³

In '46, Partington³ received a patent covering video mapping by flying-spot scanning through transparencies.

For all such systems, where the photocell sees the *crt* light source through a transparency, there are, in general, no light-level, or optical problems, but the tube itself does present quite a problem. It must have an afterglow comparable with the time-occupation of a single picture element, if it is not to degrade the definition. For a

525-line system transmitted with 4-mc bandwidth this is around $\frac{1}{4}$ microsecond. Special tubes, recently developed, can be made with afterglows around $\frac{1}{2}$ microsecond and differentiating circuitry can be used to compensate for this degree of disparity.

Few attempts appear to have been made to generate high bandwidth video signals from pictures, writing, or opaque subjects by *crt* flying-spot methods. Much of this may have been due to plain scepticism, but may also have been attributable to the optical problems involved.

For such a system, the photocell must look at the subject from the same side as the *crt* scanner, and the light it receives will not only be reflected but dispersed, and consequently of very low level.

A large optical system is required, of very high precision, able to collect every available lumen from the face of the tube and focus it with great accuracy over the entire planar area to be scanned. This calls for tube and

¹German patent 30105; Jan. 6, 1884.

²British patent 387,536; March 27, 1931.

³Techniques evolved by EMI and Cintel.

optics to be developed in conjunction, and would be prohibitive on a purely speculative experimental basis.

This problem had, however, been largely solved in advance by the development of a TV projection optical system^b and tube.

Origin of the Telescribe

The original stimulus for the equipment was not, however, provided by any desire to generate pictures from opaques, but with a view to video mixing; to overprint aircraft identification letters and tracks on *ppi* radar displays.

Such a requirement had been expressed in 1950 by the Air Traffic Control Experimental Unit (Ministry of Civil Aviation) at London Airport. The existing method, of marking aircraft letters and tracks on the face of a radar tube with a chinagraph pencil, was unsatisfactory, since such information was not then available to parallel tubes or operators. Above all it could not be relayed to remote points.

To solve the problem flying-spot scanning methods were suggested, used in the following way: A projection TV optical system to be employed with rotating *ppi* type coils, to scan the underside of a sheet of plate glass, situated adjacent to the radar tube. A photocell, also on the underside, would pick up light reflected from any white writing made upon the glass. By means of a pantograph, information written on the face of the radar tube would be duplicated on the upper side of this plate glass in white chinagraph pencil, thereby giving rise to video signals in the photocell. The time base and rotating coil system of the scanner should be synchronized with those of the radar tube, so that the photocell signals would be in correct time-relationship to the *ppi* signals and could be *mixed* in the *ppi* video stage. By this means, the original, and all parallel tubes, would *paint* the written information, and the mixed video signal could be relayed as required.

A prime requirement met by the suggested method was rapid erasure of information, by simply wiping the glass. Scanning *through* the glass would have been unworkable, since both writing and erasing instruments, or pantograph and operator's arm, would have ruined the display.

The scheme outlined was not tried immediately owing to lack of Civil Aviation funds.

A year later, however, the author was asked for an electronic development to exhibit at the London Radio Exhibition. This problem was selected from a number, as being worth developing,

and funds were made available for the project. A string-and-sealing-wax model was produced in about two months, which proved the feasibility and practicability of the principles, and also provided a good exhibit.

The Model

For simplicity and display purposes the scanner was tied to a domestic TV receiver instead of a radar receiver, and normal xy scanning was used. The pantograph was omitted, and the scanner functioned as a TV picture generator, the video signal fed into the TV set and reproducing chinagraph writing made by the public on the glass, or photographs, pictures, etc., laid face down on the glass. It also transmitted human features quite passably.

The model was based on our 405-line (202½ interlaced) TV practice, and the viewing unit was a modified domestic TV receiver. The time available was so short that, for simplicity, no attempt was made to interlace, and it therefore operated on 202½ lines only.

In the scanning unit, an area 14" x 12" of the sheet of glass was scanned with a standard TV projection^b optical system, at a distance of 27". The latter was mounted on the main chassis directly beneath the glass and no folding mirror was used. Much larger areas can be scanned with appropriate optical corrector plates.

The tube used was specially developed; it was a very short (½ micro sec) persistent version of the MW6-2^b projection aluminized tube and operated at 25 kv. The apparent light output, incidentally, was very low, deep blue in character, and gave practically no general illumination of the subject.

The *hv* was provided by a pulsed oscillator with a voltage trebling unit, as used in domestic projection receivers, and the tube was protected by safety circuits to *kill* the *hv* if either time base failed. Multivibrator-locked, blocking oscillator, timebases were employed in the scanning unit and sync signals from the multivibrators were passed to the receiver timebases. The time-factor was such that no attempt was made to lock line and frame time together, and the drift which sometimes occurred, gave the effect of slight noise.

A 350-v power line supplying the 25-kv unit, the multivibrators, the timebases, and the tube focus coil was stabilized.

A multiplier photocell was automatically assumed to be essential, on account of the low level of reflected light expected. The low apparent light output of the scanning tube confirmed this

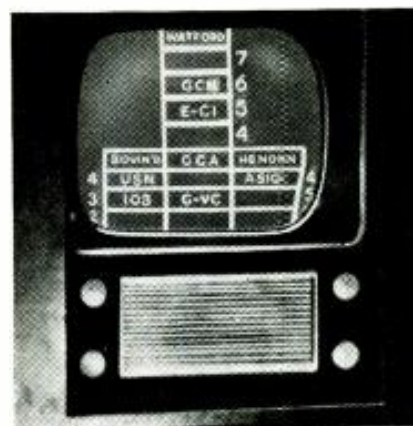

Figure 2
AIRCRAFT stack information reproduction on Telescribe.

conviction, and all work on the model was, in fact, carried out with either a 931A or an eleven-stage 5339^c. The caesium/antimony cathodes of these cells were ideally suited to the spectral output of the tube. The 5339, which has a louvre-type multiplier, was finally used in the model, since it was found to have a lower noise content. Observations with these cells, however, have since led to the conclusion that if possible, secondary emission cells are to be avoided for such applications.

Approximately 1100-v of separately stabilized *hv* was applied to the photo-multiplier; about 100-v per stage. A variable anode load resistor was provided, in parallel with a stepped control, to provide a wide range of video gain control. This was found necessary to cope with wide variation in the multiplier sensitivity, under varying ambient light conditions. It is worth recording that the multiplier was usually working

Figure 3
RECEIVER unit chassis.



^aBritish patent 624595; July 16, 1949.

^bMullard

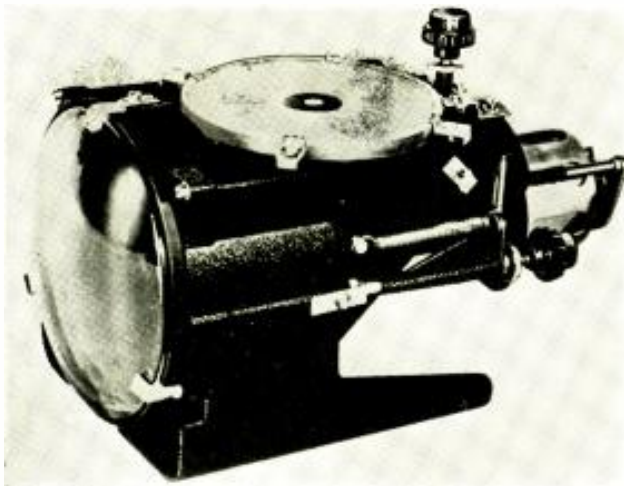

Figure 4 (left)
OPTICAL TV projector.

Figure 5 (above)
PROJECTION scanner tube.

with less than a 1-ohm load, and never more than 20 ohms.

The output of the multiplier was fed into a 4-stage video amplifier located alongside. The final stage was a cathode-follower, feeding the video signal into an 80-ohm line to the receiver.

At the receiver, the short time-constant *if* video detector was modified to operate as a long time-constant *black tip* video *dc* restorer, and the signal was fed into this point. A line-clamping circuit was also added to cope with drift effects and supply-frequency troubles.

A simple blanking circuit was added to blank out the picture tube during line and frame flybacks of the scanning tube.

While it was very convenient to add both line clamp and blanking circuits at the receiver, it would have been more logical to apply them at the scanner.

Blanking has since been applied in the video amplifier, and line and frame sync generators have been locked and mixed with the video signal in a typical TV waveform. This permits single-wire working or modulation on to a *rf* carrier.

Difficulties Experienced

Among the inevitable run of difficulties experienced, a particular one was that of *direct reflection* from the glass surfaces, and, in fact, from the surface of any picture or photograph; glossy or matt. As illustrated in Figure 7, the scanning cone, focussing at the glass, and sweeping from *abc* to *abd*, will always produce considerable direct reflection from glass or subject within the area *ecdh*.

If picked up by the photocell, this produces a large bright spot in the picture, corresponding to the point on the glass or picture, from which the *directly* reflected light actually falls

upon the cathode of the photocell. It can be avoided by placing the photocell well outside of *ecdh*.

This, however, introduces serious disparity in the amount of wanted light received by the photocell from points *c* and *d*. It gives the effect of *shading* across the picture and must be compensated.

One way tried was to position a mirror at *lm* (Figure 8), hood the photocell, and allow it to *see* the plate glass only by reflection in the mirror. By this means, the disparity in optical paths from the photocell to *c* and *d* was greatly reduced.

Better results can be secured by using four photocells in parallel; disposed along each of the four sides of the writing area.

Electronically, it is possible to apply a sawtooth voltage to the grid of the scanning tube to *shade* the raster inversely in compensation. It is no doubt possible to apply a sawtooth *agc* voltage to the photocell-video amplifier.

Reference has already been made to the multiplier photocells used, and the later conclusion that secondary emission is to be avoided.

It was found earlier that the photo-multiplier output was very greatly re-

duced if any ambient light reached it. This is a secondary emission *slope* effect and though inconvenient is neither surprising nor serious.

What *was* of serious importance, however, was a marked increase in noise. This appeared to be directly related to the current drawn by the multiplier anodes. With zero ambient light, noise was insignificant.

In spite of these effects the equipment printed from writing and pictures under almost unbelievable conditions of exhibition lighting, and the conclusion, now being tested, is that use of an ordinary photocell followed by a good, low noise, high gain, video amplifier, should make it almost independent of ambient light.

It should be noted that the method of scanning by reflection is peculiarly helpful in this matter of ambient light. So far as printing from pictures or photographs is concerned, and assuming an otherwise enclosed case for the scanner, the only entry for light is via the glass *window*. This window is, or can be, closed by the picture itself.

On the other hand, of course, while the window must be open to transmit any writing being made upon the glass, noise is not then important. In any case, high contrast is then permissible and *soot* and *whitewash* makes very good writing. Furthermore, top and bottom clipping can be used to make message transmission 100%.

Reference has also been made to *supply-frequency* troubles, and to a line-clamping circuit added in the model. Considerable annoyance was experienced from supply-frequency components in the video signal, causing interference with the picture. These experienced from supply-frequency *pickup* by the photocell, from power supplies, etc.

The line-clamp circuit, which was added in an attempt to clear other

Figure 6
HV 25-kv unit.

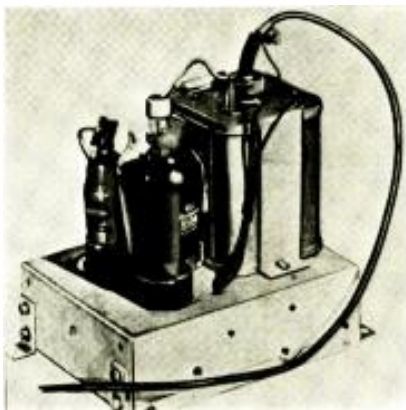

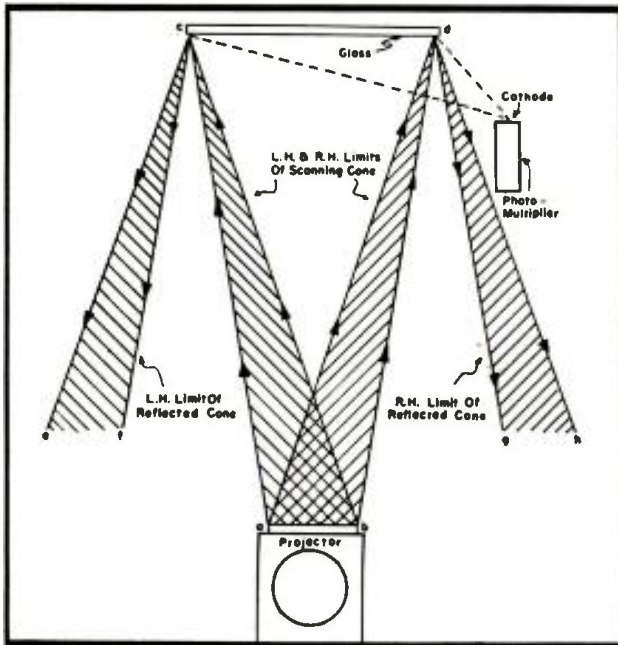

Figure 7 (left)
REFLECTION PROBLEM LEMS system was designed to overcome.

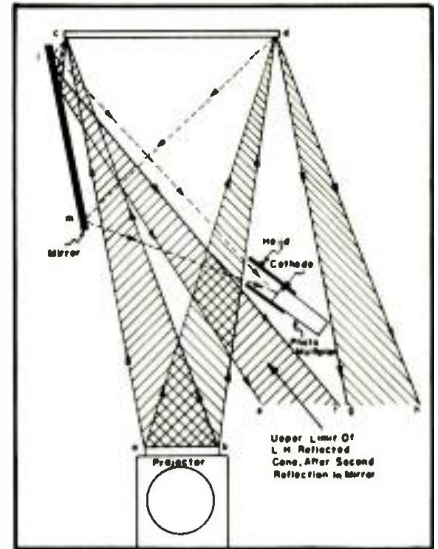

Figure 8
REFLECTION PROBLEM solution.

problems, dealt quite effectively with these troubles.

It has, however, since been concluded that good screening, and effective filters in the video amplifier, will eliminate all but the most vicious components of the supply frequency. Mercury, sodium, or fluorescent vapor lighting can, however, be troublesome.

Applications

The principle of *scanning by reflection* being proved practicable, the Telescribe was foreseen as having quite a wide field of application in various forms, and this has since been substantiated. Many of these lie in the field of closed circuit television.

The top limit of definition of the system, as discussed, is around 1000 lines, limited by scanner-tube spot size, and by the optical system corrector plate, but for the majority of industrial purposes half this lineage will suffice.

At 25 pictures (50 frames) per second the video signal can be piped by coax line over many hundreds of yards before phase shift causes difficulties, and by modulating onto a low frequency carrier, the distance may be increased to many miles.

For the transmission of fixed intelligence, however, the frame speed may be reduced to as low as one in 10 or 20 seconds, *provided that a long after-glow tube is used in the receiver*. With a frame repetition of one in 10 seconds the transmission bandwidth is reduced to 1/250 of the normal value, and for a 525-line picture this is around 16 kc only.

By this means, fixed intelligence may be transmitted *over a telephone pair or even plain wires* for a very great dis-

tance. Coast-to-coast transmission by low-frequency carrier is possible, and transocean transmission on high frequencies is straightforward.

For radar purposes, using rotating coils on the scanner, the system is quite suitable for the original aircraft purpose.

In addition, it is invaluable for video-mapping or overprinting of maps on radar displays. In this respect, it is more adaptable than the transparency method, since existing printed maps may be used. By video reversal, a black and white map will print white on black. The ease of over-fitting maps is apparent, and scanning amplitude controls will allow the map to be blown up or down as required. This has application to marine and naval navigation.

The most urgent and immediate use to which the unit has been put by the Air Traffic Control Experimental Unit has, however, been in the simple *xy* scanning form of the model. The model was, in fact, set up for the British Commonwealth Conference on Gas Turbine Navigation.

This application is mainly as an instantaneous data transmission system between the various radar operators and controllers involved in the handling of a dense flow of high-speed aircraft over a large area. For such purposes the telephone is too slow, too peremptorily disorganizing, and has no *storage*. Telephone system and users alike, saturate at peak periods. With the aid of the *Telescribe*, however, data on the positions and heights of aircraft may be transmitted immediately, silently, and simultaneously, to all officials concerned or interested. Aircraft may be *handed on* and *cleared* from area to

area, in silence, with very great time-saving and very great reduction of human error.

It is expected that the scanner will be used in this way to transmit information between airways controllers, radar controllers, zone controllers, approach controllers, *gca* controllers, aerodrome controllers, and ground movement controllers.

It is also hoped to achieve a very great speedup in the distribution of metropolitan weather information to all such controllers.

In addition radar operators may transmit *filtered* radar information by overmarking prepared maps on an *xy* scanned screen.

For many such purposes, the low frame speed and low bandwidth principle, will make transmission an economic possibility.

The application to military airfields and aircraft carriers will be apparent.

The scanner is already being explored in TV broadcasting as a more adaptable, more convenient alternative to the super *iconoscope* or *image orthicon* for caption writing, *effects*, *backgrounds*, *overwriting* etc. It would seem to appeal to producers as a personal tool they can have right under the hand.

Uses on board ship have been discussed, for instance, between captain and bridge.

While it may be far-fetched to suggest its use for TV telephone systems, the system provides transmission of human features quite well. The optical system used gave sharp focus over a depth of 1" and fair detail over some 3" to 4". By changing the

(Continued on page 26)

RCA's TV "Basic"

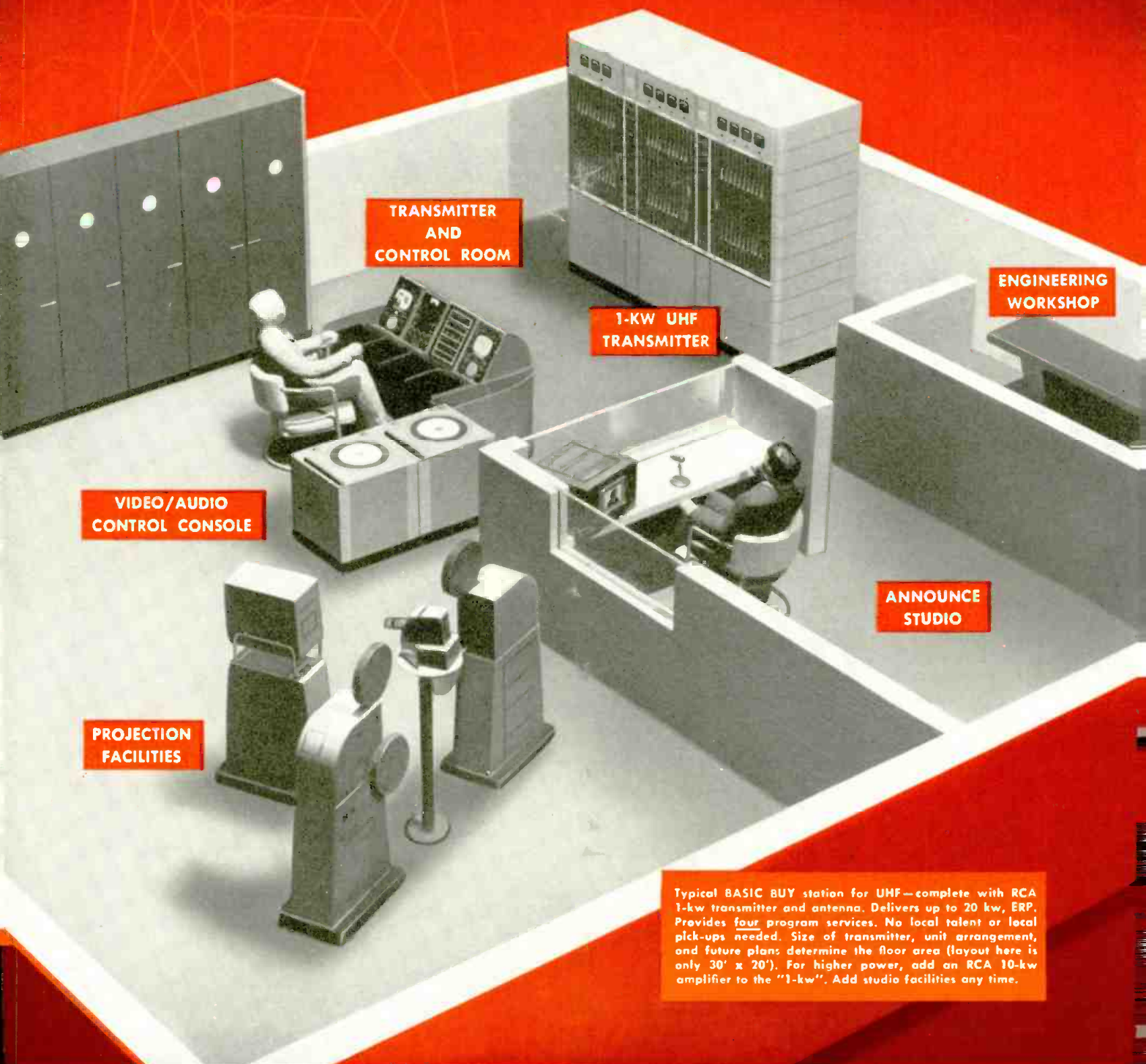

TRANSMITTER
AND
CONTROL ROOM

1-KW UHF
TRANSMITTER

ENGINEERING
WORKSHOP

VIDEO/AUDIO
CONTROL CONSOLE

ANNOUNCE
STUDIO

PROJECTION
FACILITIES

Typical BASIC BUY station for UHF—complete with RCA 1-kw transmitter and antenna. Delivers up to 20 kw, ERP. Provides four program services. No local talent or local pick-ups needed. Size of transmitter, unit arrangement, and future plans determine the floor area (layout here is only 30' x 20'). For higher power, add an RCA 10-kw amplifier to the "1-kw". Add studio facilities any time.

BUY' does the most

**-with the least TV equipment
-VHF or UHF!**

4 PROGRAM SERVICES

- no local studios needed!

- Network programs
- Local films (16mm)
- "Stills" from local slide projector
- Test pattern from monoscope (including individualized station pattern in custom-built tube)

THIS PICTURE ILLUSTRATES what we think is the minimum equipment a TV station should have to start with—and earn an income. The arrangement can handle any TV show received

from the network and provides station identification and locally inserted commercials as required. In addition, it offers an independent source of revenue—by including film and slide facilities for handling local film shows and spots, or network shows on kine recordings.

The BASIC BUY includes: A transmitter and an antenna (necessary for any TV station); monitoring equipment (required by FCC); film and slide equipment (for local programs—and extra income); monoscope camera for reproducing a test pattern of known quality (important for good station operation and as an aid to receiver adjustment); and a control console that saves operator time and effort (it enables one technical

man to run the station during nearly all "on-air" periods).

RCA's BASIC BUY can be used in combination with any RCA TV transmitter and antenna, of any power—VHF or UHF. Matched design and appearance make it easy to add facilities any time (you need never discard one unit of a basic package). And note this: *RCA BASIC UNITS ARE IDENTICAL TO THE RCA UNITS USED IN THE BIGGEST TV STATIONS!*

RCA's BASIC BUY is already being adopted by many TV station planners. Let your RCA Sales Representative work out a flexible package like this for you—show you how to do the most with the least equipment!

This is what the BASIC BUY includes!

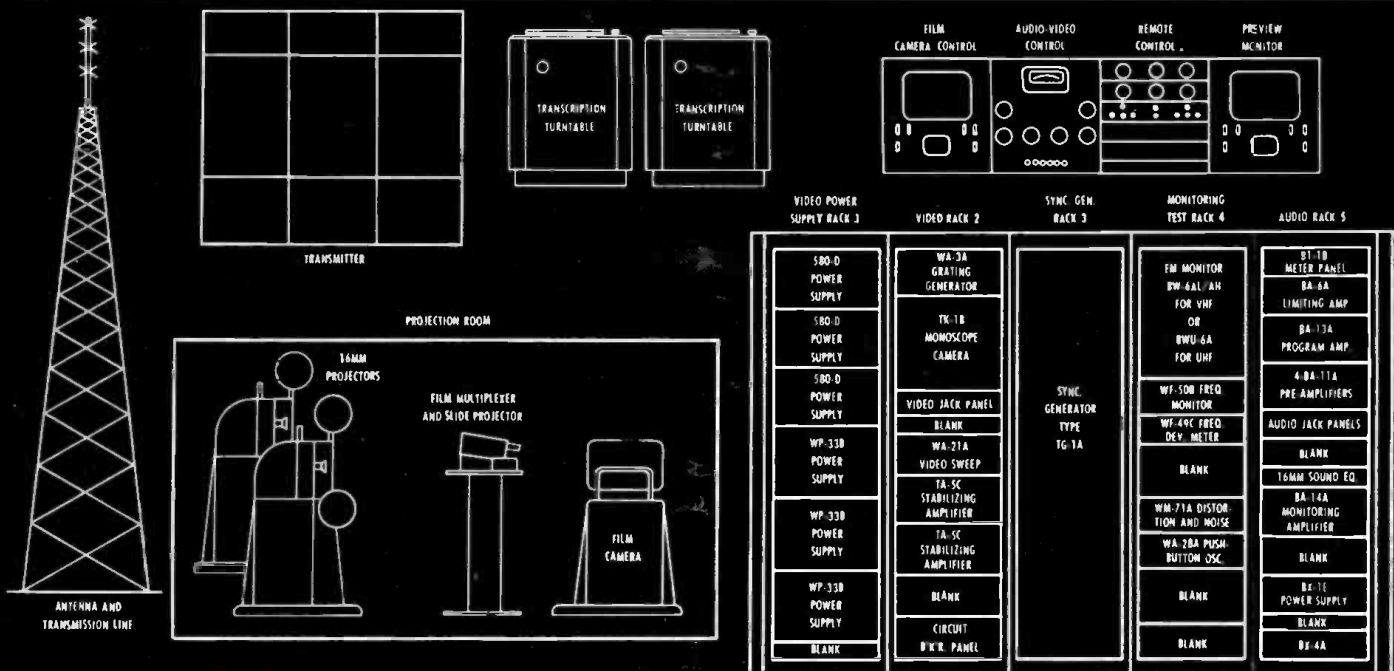

RADIO CORPORATION of AMERICA
ENGINEERING PRODUCTS DEPARTMENT
CAMDEN, N.J.

(Continued from page 9)

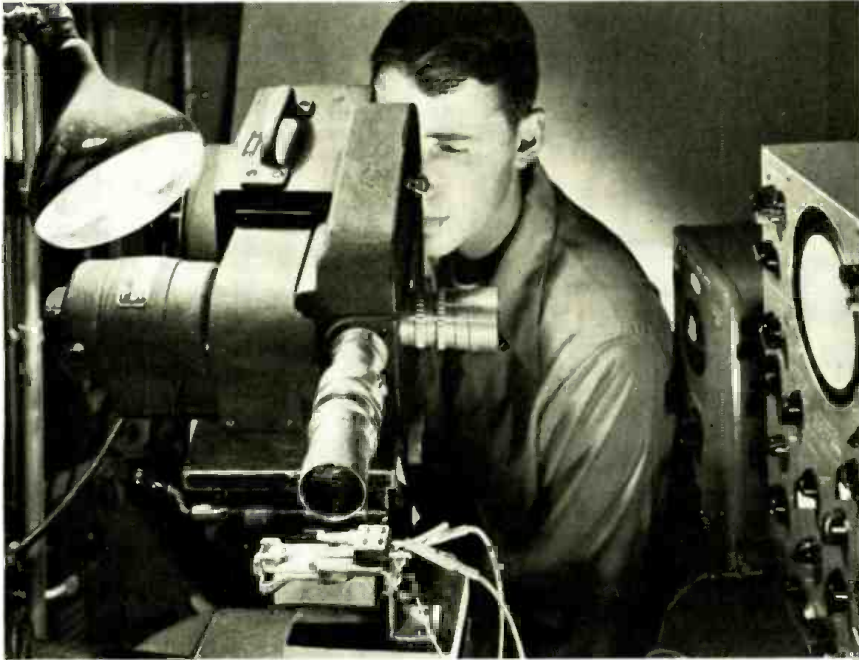

Modification of high-speed camera which permits both the mechanical and electrical aspects of a subject to be recorded simultaneously on the same film. Modification consists of the addition of a second lens to the camera to record the images on the tube of a 'scope through the back of the film, while the mechanical aspects of the subject are being photographed on the front. This record will permit the photographer to present a complete picture of the behavior of electro-mechanical devices, and will also permit correlation with strain, acceleration, vibration, and other signals fed to the 'scope in many non-electrical problems. Inasmuch as the film is traveling in a vertical direction the horizontal deflecting circuit alone is used. The film speed, as indicated by an edge-marking argon lamp in the camera, provides a time base if necessary. Exposure of the 'scope trace is continuous, not intermittent like the exposure of the picture image. On any given picture frame, the midpoint from top to bottom of the trace coincides with the midpoint of the exposure time of the picture image. The entire trace from top to bottom of the frame represents a time interval equal to the reciprocal of the picture frequency. This is five times the picture exposure time. A 'scope providing a total accelerating potential of 10 kv or higher is recommended. A P11 phosphor affords highest trace density, while a P5 phosphor shows less tendency toward blurred traces in handling very high speed transients. P15 and P16 phosphors are also useful for high speed transients. (Courtesy Eastman Kodak.)

Typical uses for reinforced alkyd molding compound, a fiber glass-filled resin which can be molded by standard plastic methods at high speeds. Plastic is said to have impact strength, plus high heat resistance, extreme dimensional stability and good electrical properties. It is supplied as a complete molding material and may be straight compression or transfer molded.

(Courtesy Plaskon)

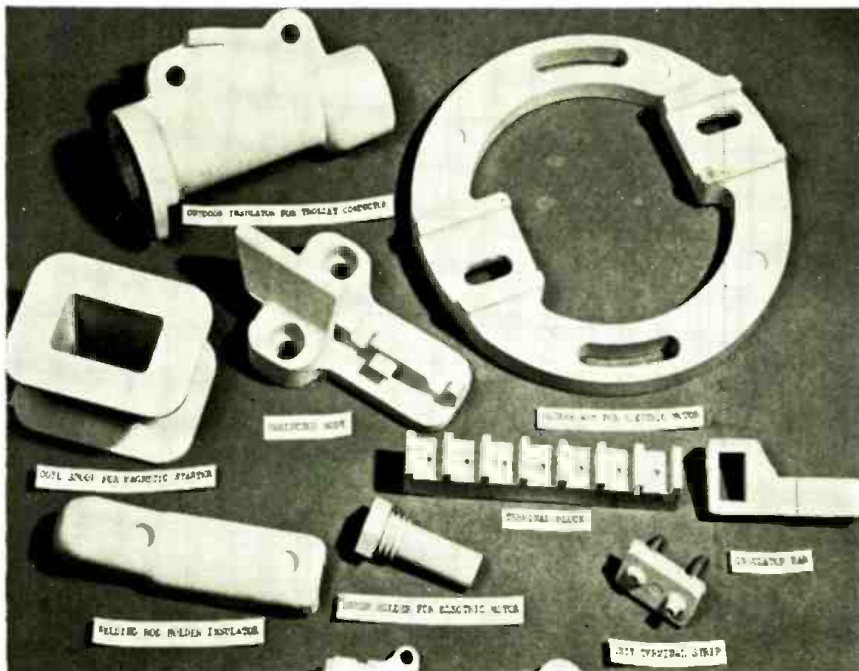

into two major portions. The first is an *rf* assembly which is the tuner and its associated circuitry. Three sections are used, allowing an oscillator tuned circuit with a 6AF4 triode, a mixer tuned circuit with a 1N72, and a preselector. A double ended capacitive coupling system feeds the preselector circuit. The oscillator was described as essentially a Colpitts circuit, with coupling from the oscillator through a .68-mmfd capacitor to the mixer. An output, from the mixer, of approximately 82 mc is fed to the *if* input. The trimmers in the *rf* and mixer were noted as being set on 460 mc at 270° clockwise rotation; the tuner is set 0° in a counter-clockwise direction and end inductance strips adjusted. The oscillator runs at approximately 82 mc below desired *rf* frequency.

In a review of performance it was said that although a gain figure of 1 has been listed, the gains have run to 3. On the basis of noise measurements made with the noise diode system, it was noted, noise figures of below 22 db have been obtained. Spurious responses in all cases were said to be down in excess of 34 db. It was indicated that measurements at various frequencies showed that rejection was from 50 to 60 db; image rejection at 890 mc was noted as 34 db, the worst point.

Describing studies on a combination *vhf-uhf* unit under way, Melvin said printed circuits, following the required complex configurations, have been tried. This printing consisted of a die stamped, pressed powder pattern with the basic metal coined into a homogeneous mass. In this instance, with the use of silver powder, conductivity better than half that of strip silver of the same cross sectional area was said to be obtained. In addition, it was noted, a smoothness of surface area was possible, allowing noise-free operation with sliding contacts.

An *rf* plate, using this process, with a basic pattern printed on 270° of the surface effectively was found to allow 360° rotation of the contactor.

During the tuner studies, several types of tubes were tried. Preliminary design was made around the 2018* version of the 6AF4. This differs from some 6AF4s in that the cathode lead inductance is at a minimum. Another tube that has been found to offer promise is the 1553D**. The recently announced 2103* was noted as offering

*G.E. **Sylvania.

(Continued on page 29)

Merchandising Education Via TV

**Pay-As-You-Earn Plan* Featuring Scrambled Video or Audio Techniques Proposed to
Eliminate Financial Problems Posed by Education Telecasts**

THE RECENT DRIVE TO BOOM EDUCATIONAL TV has had stimulating results. Teachers, scholastic leaders and association groups have praised the move, citing TV as a foremost aid in modern training.

Unfortunately, though, there has been one disturbing element: the economic aspects of the idea. Where, many have asked, will funds come from to purchase the equipment, provide for the maintenance of the stations or the establishment and continuance of a progressive program department. And how, it has also been asked, will it be possible to continue telecasting to avoid a deficit operation.

In efforts to find a practical solution to these knotty problems, both TV broadcasters and manufacturers have pondered and pondered. Recently, there appeared one plan, which seems to be a plausible approach to the difficulty.

Featuring the use of merchandising techniques, plus a novel technical distribution system, the plan provides for the setting up of a statewide network of ultrahigh stations, owned by a non-government group, which would transmit educational programs only.

During a large percentage of operating hours there would be telecast courses, in which either the audio or video would be scrambled. Students who wish to participate in one or more courses would apply for a small unscrambler code or circuit card, available on a course-fee basis.

Costs for any course would, over a period of time, decline below the orig-

inal presentation cost; each session could be recorded on film and repeat presentations of the course in the same area or presentation in other areas would thus involve no cost other than film prints. Such films could also be sold or rented for similar educational use in other parts of the country.

According to the plan, a percentage of the earnings would be routed to the state for educational uses. The state would also be permitted to broadcast a series of programs without charge, which would not involve the scrambling technique. In addition, state educational authorities would be consulted in preparation of all program material.

The proposal also notes that the majority of courses presented on the pay-as-you-learn plan would be of a day-to-day usefulness type rather than college credit courses. Typical courses could be: Supervising Manpower; Better Salesmanship; Business Personality Improvement; Operating a Small Business; Starting a Business; Theory and Practice of Transistors; Maintaining Your Automobile; Repairing Home Appliances, etc. Obviously this list can be multiplied many times, extending to both specialties and necessities common to the requirements of the majority of people.

The educational plan also covers the personnel and training equipment that would be issued; Visual aids would be featured. Courses would be given, not only by professional educators, but wherever possible by outstanding, practicing members of the businesses and professions involved. During each

course, several typical individuals who are in positions to approve, buy from, sell to, and otherwise deal with students, would be presented.

Each course session could be attended in the studio by a small group of students, who would answer instructor's questions, make comments, and contribute to the instruction by representing all the students who are at home.

Special equipment, structures, and locations would play quite a role in this plan. For example, films and TV cameras could be very helpful in a course on understanding atomic energy; the camera could bring the student to and inside such atomic gear as a cyclotron.

To stimulate interest in the plan, a continuing promotional program is suggested. Booklets would be mailed to each student to accompany the course. These would contain a brief outline of each session; statistical, graphical, and similar information for permanent retention; tear-out, five-question, multiple-choice quiz for completion and mailing after each session. (Questions would revolve about situations so that parrot-like learning would not suffice. Based on the information given in each session, the student would be required to state his procedure under certain circumstances.) A tear-out examination for the course end would also be provided.

According to the plan, each student would receive a certificate for courses satisfactorily completed. So that these certificates might carry some recognition and perhaps be used to establish subject familiarity in seeking employment or a promotion, some type of state approval of the certificates might be sought, the plan suggests. Adoption of this type of pay-as-you-learn scheme, properly administered, could be the answer to those dollar problems posed by many. —L.W.



*Plan originated by Ira Kamen, co-author of *TV and Electronics as a Career*.

Ira Kamen, second from left, and experts who assisted in the preparation of the *TV and Electronics as a Career* book which inspired the development of the proposed TV education plan: Richard H. Dorf; Kamen; John F. Rider (publisher of book); William H. Bohlke, manager of custom services, RCA Service Corp.; I. R. Poppele, chief engineer and vice president, WOR, WOR-FM and WOR-TV. R. W. Peterson, assistant manager of electronics division of Admiral, also prepared data for the book.

Grow up to a —

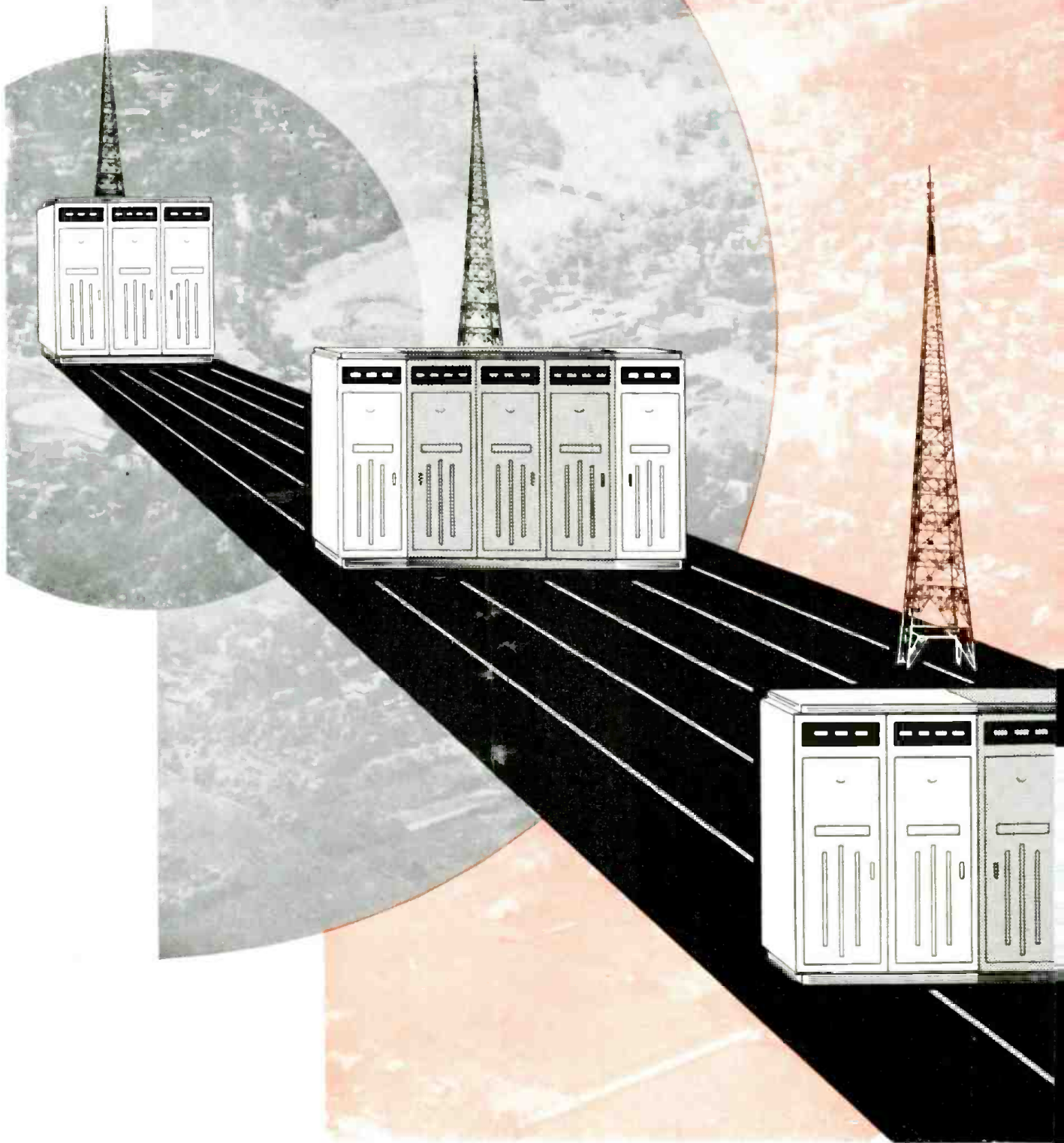

high powered future

IN TELEVISION

When the time comes for you to consider high power, whether you are on the air now and wish to increase your power, or whether you are making application, it will pay you well to consider Du Mont. An investment in Du Mont — a Du Mont high-power transmitter is *your* investment in the same long-term operational advantages...the same low costs...the same reliability that has been proved by the Du Mont Acorn 500W and the Du Mont Oak 5KW transmitters.

Du Mont offers two outstanding high-power transmitters — the Series 9000, 20KW low-band — the Series 12000, 40KW high-band.

Either of these transmitters driving a high-gain antenna will easily meet the maximum FCC allowed ERP of 100KW for the low-band and 200KW for the high-band.

The Series 9000 low-band transmitter employs intermediate-level modulation for most economical utilization of available tubes and features the time-proved Oak Transmitter driving a single power output tube in each of the Aural and Visual Transmitters.

The Series 12000 high-band transmitter contains the Oak Transmitter driver but utilizes a single r.f. power output tube in the Aural Transmitter and a pair in the Visual Transmitter.

No matter what power you require, consider Du Mont first for a long range, economically-sound investment. Du Mont protects your investment through minimum obsolescence.

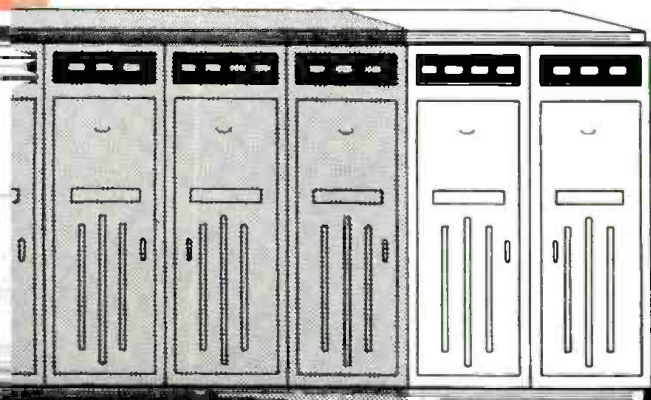

DU MONT

TELEVISION TRANSMITTER DIVISION
Allen B. Du Mont Laboratories, Inc., Clifton, N. J.

WRITE Dept. TVH
FOR BROCHURE

Production Aids

Soldering Iron

A SOLDERING IRON, for use in close quarters, has been announced.

Iron, which features an iron-clad corrosion-resistant working surface, is 10½" long, has a 5/16" shank and a ¼-inch tip. Iron is heated by a Calrod* heater which protrudes into the tip, and is said to result in a quick heat-up and rapid recovery for the iron in operation. Weighs 8½ ounces and is rated at 60 watts, 120 volts.

With all parts interchangeable for repair, the iron's tip and heater assembly are assembled and disassembled from the handle. In addition, the iron is equipped with a flanged plastic handle, so that it may be laid down temporarily without need for a stand.—*G. E. Industrial Heating Dept., Schenectady, N. Y.*

Magnetic-Wire Container

A CONTAINER, made of two identical parts of molded fibre, for the packaging of magnetic wire, has been developed.

Container, weighing 1/3 the weight of the old-style box type, features a tray-like case that cradles the spools of magnet wire, yet makes them readily available for use. Customer need only remove the top cover and then lift the lower tray to the storage shelves.—*Anaconda Wire and Cable Co.*

Three-Dimensional Calendaring

THREE-DIMENSIONAL CALENDARING, a process involving the feeding of a series of bare wire, together with Teflon powder, into the nip of two calendar rolls which have been grooved to permit passage of the wires and to provide the pressure required for the cold-forming of coatings around the wires, has been introduced.

Coatings, between 15 and 50-mils thick, are said to be simultaneously applied to almost any number of wires. Wires are fed through straighteners and a series of paralleling guides before entering the bite of the calendar rolls. Powder is fed by means of a vibratory hopper. Entire coated assembly is passed into a sintering oven or bath where the coatings are fused at about 750° F.—*Described before the Society of the Plastics Industry Conference by Wilton A. Hawkins, E. I. duPont de Nemours and Co., Inc.*

Panelboards

SELF-SUPPORTING INSTRUMENT AND CONTROL PANELBOARDS, which are made of formed steel, have been announced.

One unit, usually 3/16" to ¼" in thickness, with return edges at top and bottom of 2", have side wings from 12" to 18" or wider which serve as a support member and can also be used to mount terminal blocks and other electrical or mechanical equipment. Doors and top can be added to the unit.—*Deep Wing Panel; Falstrom Co., Falstrom Court, Passaic, N. J.*

*Reg. Trade Mark.

Strain-Relief Bushing

A NYLON STRAIN-RELIEF BUSHING for wires passing through sheet metal, spun or cast iron, has been announced.

Bushing is said to absorb wire pull-push and torque, eliminate special grommets, tapping and wire knots, provide insulation at the entrance hole, and lock the wire in place.—*Heyman Manufacturing Co., 100 Michigan Ave., Kenilworth, N. J.*

Insulating Compound

AN INSULATING COMPOUND, that is said to be suitable for operating temperatures of -60° C to +120° C, has been developed.

Insulated wires using this compound are available for high-temperature and baking operations, such as transformer leads, motor leads, coil and relay leads, and for confined areas involving temperature build up.—*HLT500; Chester Cable Corp., 521 Fifth Ave., Chester, N. Y.*

Parts Duplicator

A PARTS DUPLICATOR, which through the use of an electronic robot that feels the contours of a master pattern and can produce hundreds of parts that are said to be the exact duplicates of the original, has been developed. Duplicator has been used in turning shafts, bearings, mill rods, commutator rings, die sinking operations, and in producing cams or complicated design on milling machines.

Unit consists of a follower, an electronic control unit and an output-drive motor. Follower is a variable reluctance transducer whose electrical output varies in accordance with the contours of a template. Signal is amplified and detected in the electronic control unit, providing drive to the output motor. Motor, in turn, positions the follower and cutting tool.—*Raytheon Manufacturing Co., Waltham, Mass.*

Grounding Sheath Connectors

GROUNDING SHEATH CONNECTORS, that are two-piece compression types for terminating braided shields on wires and cables used in radar, rf and af circuits and for uhf applications, have been developed.

Connector consists of a pair of tubular sleeves, a short soft-metal outer and a longer hard-metal inner. Inner sleeve slips either under or over the braid, the braid and grounding lead are assembled between the inner and the outer which is then compressed to secure the braid and ground lead, forming a connection between the strands of the braid and ground lead.

Ground lead may be inserted from either direction. Special terminal tongues may be used in place of the ground wire. Tools for installing these connectors are also available.—*The Thomas and Betts Co., Inc., Elizabeth, N. J.*

Test Panels

TEST PANELS, featuring meters, time clocks, switches, phase shifters and cables for testing to military specifications, have been produced. Panels are used to check the complete operational properties of electronic gear.—*Sterling Instruments Co., 13331 Linwood Ave., Detroit 6, Mich.*

Subminiature Slipring Assembly

A SUBMINIATURE SLIPRING ASSEMBLY, that incorporates 32 sliprings with individual, colored leads, has been introduced.

Overall length of the assembly is 1.011". Ring sizes provide for a width of .020", barrier width .010", and ring diameter .141". Assembly is said to meet insulation requirements of 500 volt hipot, intercircuit. Rings are hard silver, and finished with palladium and rhodium or gold.—*Electro Tec Corp., South Hackensack, N. J.*

Small Size Latching Relays

A SERIES OF LATCHING RELAYS, featuring smaller size, higher contact capacity and high vibration resistance, have been announced.

Available in both open and hermetically sealed types, the relays can be provided with contacts up to *dpdt* on a latching relay and *dpdt* on a release relay. A minimum of 35 grams contact pressure is said to assure positive make or break under vibration forces of 10 G or higher. Relay contacts are ¼" fine silver rated at 5 amps or can be supplied on special order with 3/16" silver cadmium oxide, rated at 10 amps.

The open type relay measures 2 15/16" long, 13/16" wide and 1¼" high. The hermetically sealed relay is 3 1/16" long, 1 3/16" wide and 2 3/16" high and is fitted with an all-glass solder terminal header.—*LK series; Potter and Brumfield, Princeton, Indiana.*

Copper and Aluminum-Clad Laminated Plastics

COPPER AND ALUMINUM-CLAD LAMINATED PLASTICS sheets, which can be used for printed circuits, have been developed.

Sheets are available in 36" x 42" sizes, in thicknesses from 1/32" to 3/32" inclusive. Metal foil thicknesses are 1½ and 3 mils. Sheets are available with metal covering on one side or both sides.—*T-725, T-812; The Richardson Co., 2765 Lake St., Melrose Park, Ill.*

Toggle Switches

WATERPROOF TOGGLE SWITCHES that open and close electrical circuits under water, and are said to function from 65° below zero to 165° above and withstand salt spray, shock and vibration, have been developed.

Switches are furnished with ratings of from 20 to 200 amperes, in toggle arrangements of momentary *on* or *off* and stationary *on* or *off*, with one or two-hole mounting. Switch body is encased in a molded rubber compound. Waterproof lead wires are vulcanized into the rubber case and become integral parts of the assembly, as does the switch mechanism itself. Waterproof connectors are assembled to the lead wires when required.—*Riverside Manufacturing and Electrical Supply Co., 10228 Michigan Ave., Dearborn, Mich.*

TV Parts

RF Coax Switch

AN RF COAX SWITCH, that is actuated by a 24-28-volt ac rotary solenoid, has been introduced.

At frequencies to 11,000 mc, switch is said to have a maximum *vsur* of 1.5 db and less than 0.2 db insertion loss; at 3000 mc per second, crosstalk is in excess of 55 db. Power handling capabilities are claimed to be 100 watts continuous *cw* at 3000 mc; actuation time less than .5 second, with a minimum life of 10,000 cycles.—*Model 10565; Thompson Products, Inc., 2196 Clarkwood Rd., Cleveland 3, Ohio.*



Thompson RF Coax Switch.

Delay Lines

ELECTRICAL DELAY LINES, that are said to provide delays ranging up to 100 microseconds, have been announced.

A typical delay line has the following characteristics: delay time, 1.1 microsecond; rise time (from 10% to 90% of step function), 0.1 microsecond; bandwidth, 2 mc; attenuation, less than 1 db; characteristic impedance, 460 ohms; number of sections, 15; dimensions, 3/4" x 7/8" x 8 1/8".—*Gulton Manufacturing Corp., 212 Durham Ave., Metuchen, N. J.*

Heavy Twin Lead

A HEAVY TWIN LEAD, for 300-ohm applications, has been developed.

Featuring polyethylene or alathon, lead-in has a thickness of .100" with a maximum variance of .005". Leads are imbedded in the plastic.—*Plastoid Corp., New York, N. Y.*

PC Units

FOUR CAPRISTORS, a combination of capacitors and resistors, which can be used for diode filters, band pass filters, inter-stage coupling elements and other resistor-capacitor circuits, are now available. Produced as either non-insulated, with white enamel, or insulated with a thermosetting dip type coating, vacuum wax impregnated.—*Jeffers Electronics, Inc., DuBois, Pa.*

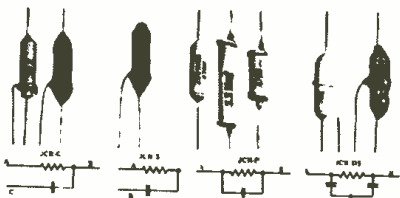

Jeffers Capristors.

Installs Instantly—

just **SNAP ON**

—stays put!



Saves you expensive production man-hours with **EXCLUSIVE** instant snap-on feature. Reduces your parts costs because priced below competition. Clamp-type construction of Hardened Spring Steel.

FEATURES OF BOTH MODELS

- **STAYS PUT**—No wobble; no shift during shipment; no realignment necessary when your TV set is installed in the home.
- **EASILY ADJUSTED**—Slides more uniformly over tube's neck due to metal-to-glass contact.
- Each individual Heppner Ion Trap **STABILIZED** and **TESTED** on special equipment designed and used only by Heppner. Guaranteed to meet your working requirements.
- **UNUSUALLY FAST DELIVERY.**
- **LIGHTWEIGHT**—Snap-On Model weighs only 1/2 ounce; Slip-On Model only 3/5 ounce. Will not harm tube's neck.
- Retains magnetism indefinitely—**ALNICO P. M.** used.



SLIP-ON ION TRAP

Installs in a few seconds. Steel construction with steel tension spring. Lowest priced ion trap on the market.

Write today for further information on better ion traps at lower prices.

HEPPNER

MANUFACTURING COMPANY
ROUND LAKE, ILLINOIS
(50 MILES NORTHWEST OF CHICAGO)
PHONE: 6-2161

REPRESENTATIVES

John J. Kopple
60 E. 42nd St., New York 17, N. Y.
James C. Muggleworth
506 Richey Ave., W. Collingswood, N. J.

Ralph Haffey
2417 Kenwood Ave., Fort Wayne 3, Ind.
Irv. M. Cochrane Co.
408 So. Alvarado St., Los Angeles, Cal.

World's Largest Manufacturer of Ion Traps

Magnetic Sound

(Continued from page 11)

any way affecting the operation of the recorder or its normal sync drive.

One of the requisites in a television programming schedule is speed. Our system has been found to be ideal in this respect. In recording a show, the projector and magnetic recorder is driven with the normal sync motors or in interlock. However, interlock is not required as the sync motors will hold constant speed for any length of time. Upon completion of the filming the picture is processed and any editing is done by the use of sync or normal editing equipment. Start marks are identified at the beginning of the scenes or of the program and threaded accordingly. In the course of fast editing it is always possible to establish a wrong start mark at either the beginning or between cuts; this hazard has been eliminated by the addition of a differential unit in the interlock circuit. The differential was installed between the projector and recording equipment so that it is possible to rotate the differential either add or subtract frames to return a scene to lip synchronization should it ever be off. This differential was mounted below our recorder. An operator can quickly judge whether the sound is leading or lagging the picture and immediately make an adjustment without interfering with the program.

This system has been in use for approximately two years on all of our cinemascope. In '51 over 500,000 feet of negative release stock were produced. With this experience we are completely satisfied with the excellent sound and the reliability of the system. It has given our program department great flexibility in operation and it certainly has improved the quality of our picture and sound releases.

Telescribe

(Continued from page 17)

corrector plate this depth may be greatly increased.

The use of the system as a cheap, low-grade facsimile system is foreseen, and police applications are visualized.

Last, but by no means least, it may be adapted as a complete TV signal picture generator. In this form it will be required by TV manufacturers and dealers, and one can foresee wide use of it in this form for publicity and display purposes.

Acknowledgment

The author is grateful to Mullard, Limited, for permission to publish this article, and to R. F. Laurence of Winston Electronics for his valued suggestions.



Specify AMPHENOL FOR QUALITY

It has taken years of constant research and development to make Amphenol the keyword in the electronics industry. Specifying Amphenol is specifying quality! From the inclusion of only the best of top-grade materials to the last rigid inspection of the finished component, nothing is overlooked in making every Amphenol connector or cable the best in quality that can be produced.

A copy of Amphenol's B-2 General Catalog will be sent on request.

AMERICAN PHENOLIC CORPORATION
1830 SO. 54TH AVENUE • CHICAGO 50, ILLINOIS

Pressure Microphone

A SEMI-DIRECTIONAL, PRESSURE MICROPHONE, for remote pickup use by AM, FM, and TV stations, has been announced.

In the microphone, sound pressure actuates a thin diaphragm to which an annular coil is attached. Coil is located in the air gap of a magnetic structure and connected to an impedance matching transformer which provides output impedances of 30/150 and 250 ohms. Voltage response of the microphone is made approximately independent of frequency over the audio range by coupling acoustic circuits to the diaphragm. Has a frequency response of 60 to 10,000 cps and an output level of 53 dbm referred to one milliwatt and a sound pressure of 10 dynes per square centimeter. For frequencies below 2000 cycles, the microphone is non-directional.

Microphone has a removable base and an adjustable ball and socket swivel, which is said to allow tilting noiselessly in any direction for the best speaking angle. It may also be used as a hand microphone, or mounted on a floor stand. Microphone is 8" high and weighs 1 pound and 3 ounces. *BK-1A; RCA Engineering Products Dept., Camden, N. J.*



RCA Pressure Microphone

16-mm TV Film Projector

A 16-MM TV FILM PROJECTOR and film camera channel has been introduced.

Projector incorporates Eastman type-25 projector mechanism. Picture roll, it is claimed, may be eliminated when switching, fading or lapping from remote signals to local stations, or vice versa. A built-in filter allows use of either black-and-white or color film. Reel capacity is two hours. Light bars and travel-ghosts are said to be eliminated by use of the electronically-pulsed xenon gas flash-lamp instead of a mechanical shutter, and extra light intensity of 250 ieu (foot candles corrected for iconoscope) is achieved.

A camera preamp design, and rack mounted channel amplifier are said to result in no microphonics or picture interference due to vibration. Camera channel has a sweep reversal switch to correct for picture reversal resulting from use of a mirror change-over; the camera accommodates either positive or negative film prints. —*Film projector, type PE-5-A, and film camera channel, type PE-5-A; General Electric Co., Dept. X-8, Electronics Park, Syracuse, N. Y.*

Projection Optical System

A PROJECTION OPTICAL SYSTEM, with a speed of 1/0.67, has been developed.

Using only the light from the face of a high intensity 7-inch TV picture tube, system projects a 25' x 19' picture on a screen 78' away.

Main elements of the system consist of a spherical reflecting mirror, diaphragm or annular ring which acts as a fixed iris, and a corrector plate which is a thin lens ground to a special curvature to correct the aberrations of the spherical reflector. This lens is 22.2" in diameter. All three fit into a projection barrel; mirror at rear, lens in front, and diaphragm approximately in the center. Picture tube is mounted in the center of the barrel.

Focal length of the system, 384 mm or 15.3", was determined by the radius of 7-inch picture tube. Ratio of geometrical apertures, efficiency of light transmission at the edge versus center, is 0.9.

Lens is made of lead glass. Spherical mirror is 26" in diameter, approximately 2" thick, and coated with a thin layer of aluminum. Projection barrel is sealed, to eliminate electrically attracted dust. A recirculating cooling system holds down temperature of the tube, which is operated at a higher voltage than in normal receivers.

Picture quality is controlled from a console panel which is set up in a remote position from the projector barrel. Reception of both video and audio signals may be either by coax cable, microwave or off the air. —*Simplex System, General Precision Laboratory, Pleasantville, N. Y.*

All-Purpose IO Camera

AN ALL-PURPOSE IMAGE ORTHICON TV CAMERA, that is said to provide longer tube life, faster and more accurate focusing, and simplified operation, has been introduced.

Features include a plug-in video amplifier with feedback output stage, high-peaking circuit, improved deflection circuits, and *locus modulation* which is said to eliminate multiplier spots.

Camera also includes provision for a filter disc back of the turret, a plug-in blower assembly which is removable from the bottom of the camera, and a ball-bearing drawer-slide mount for the coil assembly. The studio camera control panel is indirectly illuminated and uses standard knobs in place of the former rim type.

Uses an electronic viewfinder, a picture monitor using a 7-inch aluminized picture tube.

Four EKTAR type lenses may be mounted on the lens turret of the camera. These can be rotated by a handle at the rear. They are available in focal lengths from 35 to 135mm. Provision has also been made for remote iris control on the lenses. —*TK-11A; RCA.*



RCA IO Camera.

Microwave Generator

A MICROWAVE GENERATOR, for checking the performance of microwave and *uhf* wide-band receivers, has been introduced.

Thermal noise of a standard amount manufactured by a fluorescent lamp inside of a waveguide or box is used as a signal and is picked up by the receiver. Fluorescent lamp has an equivalent black body thermal temperature of over 13,000 degrees, yet is said to remain cool to the touch. —*Telechrome, Inc., 88 Merrick Road, Amityville, L. I., N. Y.*



Telechrome Noise Generator.

Voltmeter

A HIGH-IMPEDANCE VOLTMETER, which can be used at audio and supersonic frequencies, has been introduced.

Instrument features a five-step attenuator, *rc* coupled multistage amplifier, balanced rectifier and *dc* amplifier, and a special meter in which the deflection is proportional to the logarithm of the current through it.

Instrument can be used as an ammeter by connecting it across suitable resistors, or as a null detector in *dc* bridge measurements. —*1040; Freed Transformer Co., Inc., 1718 Weirfield St., Brooklyn 27, N. Y.*

Test Instruments

TEST INSTRUMENTS, including a combination sweep and marker generator, all-purpose five-inch 'scope, and a dual regulated power supply, have been introduced.

TV channel sweep combines sweep signal and markers for *rf* alignment of head-ends and overall systems. Features single knob selection of sweep and one to five marker frequencies simultaneously. A continuously variable capacitor-type attenuator has a range in excess of 100 db. Output is one-quarter volt at 300 ohms balanced or 72 ohms unbalanced.

'Scope features identical high-gain direct-coupled vertical and horizontal amplifiers, said to be flat to 500 kc; uses a driven sweep and high accelerating voltage to permit use of tubes having long persistence phosphors; has a low input capacity probe, 10 mmfd, and an internal voltage calibrator covering the range of .1 to 300 volts peak-to-peak in eight steps.

In the dual regulated power supply, each supply is independently regulated, controlled and metered from 0 to 500 volts, and up to 100 milliamperes. Hum and noise are said to be below 3 millivolts *rms*. Features electronic overload protection for both tubes and meters, bias voltages and *ac* filament supply. Regulated outputs may be modulated via an internal amplifier; regulated outputs may be paralleled for increased current ratings. —*Models ST-11A, ST-2B, ST-9A; G. E. Electronics Division, Syracuse, N. Y.*

BIRTCHEER TUBE CLAMPS

Hold Tubes in Sockets
under all Vibration,
Impact and
Climatic
Conditions

83
VARIATIONS
FOR
STANDARD
TUBES



NEW
CLAMP
FOR
MINIATURE
TUBES



You can't shake, pull or rotate a tube out of place when it's secured by a Birtcher Tube Clamp. The tube is there to stay. Made of Stainless Steel, the Birtcher Tube Clamp is impervious to wear and weather.

BIRTCHEER TUBE CLAMPS can be used in the most confined spaces of any compact electronic device. Added stray capacity is kept at a minimum. Weight of tube clamp is negligible.

Millions of Birtcher Tube Clamps are in use in all parts of the world. They're recommended for all types of tubes: glass or metal—chassis or sub-chassis mounted.

**THERE'S A BIRTCHEER TUBE CLAMP
FOR EVERY STANDARD AND
MINIATURE TUBE!**

Write for samples, catalogue and price lists.

THE BIRTCHEER CORPORATION
4371 Valley Blvd.
Los Angeles 32, Calif.

Instruments

Crystal Oscillator

A CRYSTAL OSCILLATOR, that provides standard frequency harmonics of 1 mc, 100 kc and 10 kc, with output frequencies as high as 1000 mc, has been announced. Short period stability (several hours) is said to be .0001 per cent.

Usable 1-mc harmonics extend to 1000 mc, and the 100-kc and 10-kc harmonics to at least 250 and 25 mc, respectively. Crystal frequency can be readjusted to agree with the standard-frequency transmissions from radio station WWV, or other sources.

One-mc crystal is a plated, wire-mounted, hermetically-sealed unit with a low-temperature coefficient of frequency.—Type 1213-A; General Radio Co., 275 Massachusetts Ave., Cambridge 39, Mass.



G-R Crystal Oscillator.

Indicating Instruments

INDICATING INSTRUMENTS, interchangeable with types in *ac* and *dc* ranges and the 2½" and 3½" sizes that meet the dimensional requirement of JAN-1-6, have been announced.—Phaotron Co., 151 Pasadena Ave., South Pasadena, Calif.

DC Voltmeter

A *DC* VOLTMETER, providing *dc* voltage ranges from 1 volt full scale to 1000 volts full scale, has been introduced.

Features distended *dc*-voltage ranges, *ac*-voltage and millivolt ranges of 1 mv to 1000 v, ohm ranges x 1 to x 10⁶. The *dc* amplifier will drive a 1-ma recorder, has gain of 200, and frequency range of 0 to 100 kc.—Model R-332; Southwestern Industrial Electronics Co., 2831 Post Oak Rd., P. O. Box 13058, Houston 19, Texas.



SIE Voltmeter

FREED Instruments



1010 COMPARISON BRIDGE
Self contained — A.C. operated
Rapid and accurate
test of Resistors,
Condensers, Inductors



1020 MEGOHMMETER
DIRECT READING
Self contained — A.C. operated
Electronically regulated supply
1 megohm to 2 million megohms.

SEND FOR COMPLETE TRANSFORMER AND INSTRUMENT CATALOGS

FREED TRANSFORMER CO., INC.
INSTRUMENTS DIVISION
1728-B Weirfield Street
Brooklyn (Ridgewood) 27, N. Y.
EXPORT DIVISION
458 Broadway, N. Y. C. 13, N. Y.

For professional splicing and
cutting professional recording
tape . . . utilizing a method
never before available

Check these features

**THEY TELL YOU WHY IT WILL
PAY YOU TO USE THE AMAZING
"PRESTO-SPLICER"**

- ✓ Makes a permanent splice which is not audible and requires no adhesive or cement
- ✓ Makes a clean 'butt-welded' splice permitting critical, efficient splicing, without scraping or loss of tape material
- ✓ Can be used for a variety of fields—including radio, television and motion pictures
- ✓ Eliminates the need for re-recording after editing and splicing
- ✓ Permits the most critical synchronization of tape sound track with film
- ✓ Used by leading broadcasting stations throughout the nation

The revolutionary MT-1 Presto-Splicer can build plus profits for your magnetic recording department. Write today for additional information, instruction manual and other pertinent data to:

PRESTOSEAL MFG. CORP.
38-01 Queens Blvd., Long Island City, N.Y.

IRE UHF Report

(Continued from page 20)

great promise. All of these tubes were said to be operable as mixers.

The 2018* version of the 6AF4 has also served for the oscillator design.

Tuned-Line Tuner

Another type of *uhf* tuner design was described by H. F. Rieth of Kingston Products, using a curved tuned line approach.

The line was said to be shaped in a radius to gain compactness, as well as, to simplify the slider and tuner drive mechanism. Tuning was described as being accomplished by using silver-plated sliders having zero backlash.

The overall *rf* circuit of the converter was said to consist of a stationary balanced transmission line type antenna coupling loop, a tunable preselector transmission line, and crystal mixer. It was noted that the transmission line type of antenna loop is mutually coupled to a preselector line, coupling being employed to correct the small variation of preselector *Q* with frequency to obtain a near constant loaded bandwidth. This was achieved by physically locating the loop closer to the preselector line at the *hf* end of the range. The oscillator and preselector lines were said to be made of 1/4" wide curved parallel strips of silver-plated brass. A parallel line of adjustable electrical length was noted as serving as the tuning means.

Describing the preselector circuit, Rieth said that its design was based on a halfwave transmission line developing an unloaded *Q* of 600 with complete absence of dead spots or spurious responses and having a line characteristic impedance of 125 ohms. In covering this frequency range the line shorting slider has a 4" travel. A crystal mixer is directly coupled to the output shorted end of the lines and the antenna is mutually coupled to the shorted input end of the lines.

To receive *uhf* stations between 470 and 890, it was noted that the local oscillator tunes from 275 to 695 mc when the *vhf* set is tuned to channel 10. The basic oscillator design was said to have an upper limit of 1100 mc which is much higher than required for *uhf* tuner application and being a quarter wave design is very stable.

The warm-up drift of the local oscillation at the high-frequency end of the band was said to be approximately +250 kc and approximately -250 kc on the low end of the band. The frequency was said to stabilize after approximately five minutes of operation. The maximum deviation due to line

C-D and

Faradon*
CAPACITORS

They earn their leadership
every day, in the laboratory
and in the field!

C-D transmitting capacitors and Faradon* capacitors manufactured exclusively by Cornell-Dubilier, available through all Authorized C-D Distributors. Write for Catalog to: Dept. TV42, Cornell-Dubilier Electric Corp., South Plainfield, N. J.



CONSISTENTLY DEPENDABLE
CORNELL-DUBILIER
CAPACITORS

Plants in South Plainfield, N. J.; New Bedford, Worcester, and Cambridge, Mass.; Providence, R. I.; Indianapolis, Ind.; Fuquay Springs, N. C.; and subsidiary, The Radiant Corp., Cleveland, Ohio

voltage drift was pointed out as being approximately 70 mc throughout a 95 to 125-volts range of line change.

Analyzing the *if* amplifier circuit, Rieth said a cascode type was used with a 6BK7 double triode. With the *if* amplifier aligned to *vhf* channel 10 (195 mc) and series coupled to the crystal mixer, the output of the mixer is amplified and allows the converter noise to dominate the noise of the *vhf* receiver as well as isolate the *uhf* and *vhf* oscillators from each other. This arrangement was also said to provide additional *vhf* selectivity against images of the *vhf* signal and against other sig-

nals which would introduce spurious responses. It was also noted that this system also provides extra attenuation to radiation of *vhf* oscillators.

The power gain of the *if* amplifier at 200 mc, measured as the ratio of the power at the 300-ohm output to the power into the grid of the input stage was said to be 21 db.

Detailing the performance factors of the tuner, Rieth said that noise factors of 16.5, 18.2, 19.3 and 22 have been obtained at 500, 600, 700 and 800 mc. Image rejection at these frequencies was said to be 42, 31, 24 and 14, respectively.



Measurements Corporation
MODEL 78

STANDARD SIGNAL GENERATORS

FREQUENCY RANGE: Choice of two bands; frequency ratio of each band 1.8 to 1 within range of 10 Mc. to 250 Mc. Special single band instruments also available up to 420 Mc.

OUTPUT VOLTAGE: Continuously variable from 1 to 100,000 microvolts.

MODULATION: AM, fixed at 30%.

POWER SUPPLY: 117 v., 50/60 cycles.

MEASUREMENTS CORPORATION

BOONTON  NEW JERSEY

for
SPECIAL
insulation
problems of
Polyethylene
AND *Vinyl*

... we offer our facilities for special compounds, special design, extrusion and fabrication. Consult:

Extruded Products Div.

GERING PRODUCTS INC.

Pioneers in Electronic Insulation
DEPT. TV
KENILWORTH, N. J.

Briefly Speaking . . .

ELECTRONIC EXPANSION on the west coast is booming, according to *Leon B. Ungar*, WCEMA prexy. Approximately 5,067,770 square feet of factory facilities are now being used for manufacturing and lab activities, and over 30,000 are on the payrolls. . . . The flying-spot scanner has become a feature of a new 16-mm film system. Unveiled at the recent NARTB convention in Chicago by *DuMont*, the new gear, it is said, may be run at variable speeds within limits of the sound system; may be stopped for single-frame operation; and requires no phasing to the sync generator or power line. Device can also be used as film recorder. Unit will become commercially available in from 18-24 months. . . . The complex lighting facilities required in typical studios have been effectively described in a series of bulletins and work sheets, issued by *Century Lighting, Inc.*, 521 W. 43rd St., New York 18, N. Y. . . . *Audio and Video Products Corp.*, 730 Fifth Ave., New York 19, N. Y., have been appointed reps in the United States area east of the Mississippi for the M. B. Paul Co., creators of one-piece translucent backdrops. . . . *Gray Manufacturing Co.*, Hartford, Conn., has leased 23,000 square feet of manufacturing space in the former Hilliard Mill in Manchester, Conn., to provide additional operating space for its wholly-owned subsidiary, *Gray Research and Development Co.* . . . *Teletronics Lab* has moved its general offices and main plant from 352 Maple Ave., Westbury, L. I., N. Y., to Kinkel St., Westbury. The former plant will be used as a laboratory and engineering offices. . . . *Synthane Corp.* has nearly completed its new two-story brick wing, 150' x 60', which will add 18,000 square feet of floor space to its main plant. . . . The San Francisco Bay area has 348,500 TV sets, with a penetration figure of 32.5%, according to a recent survey by the San Francisco TV stations committee. . . . *KSFO* and *KPIX* have opened new studios at Van Ness Ave., at Greenwich St., San Francisco, Calif. . . . Tin producers of Malaya have announced the opening of an information center, *The Malayan Tin Bureau*, at 1028 Connecticut Ave., Washington 6, D. C. . . . *The Staver Co., Inc.*, now has a new plant at 41-51 N. Saxon Ave., Bay Shore, L. I., N. Y.



New Staver plant.

WANTED Engineers and Scientists

Unusual opportunities for outstanding and experienced men

These top positions involve preliminary and production design in advanced military aircraft and special weapons, including guided missiles.

IMMEDIATE POSITIONS INCLUDE:

Electronic project engineers
Electronic instrumentation engineers
Radar engineers
Flight test engineers
Stress engineers
Aero- and thermodynamicists
Servo-mechanists
Power-plant installation designers
Structural designers
Electro-mechanical designers
Electrical installation designers
Weight-control engineers

Excellent location in Southern California. Generous allowance for travel expenses.

Write today for complete information on these essential, long-term positions. Please include resume of your experience & training. Address inquiry to Director of Engineering.

NORTHROP AIRCRAFT, Inc.

1035 East Broadway
Hawthorne
(Los Angeles County)
California



ADVERTISERS IN THIS ISSUE

TELEVISION ENGINEERING

APRIL, 1952

AMERICAN PHENOLIC CORP.	26
Agency: Burton Browne Advertising	
BIRTCHEER CORPORATION	28
Agency: Crossley & Jeffries, Inc.	
CORNELL-DUBILIER ELEC. CORP.	29
Agency: Itelco Advertising	
ALLEN B. DUMONT LABORATORIES, INC.	22, 23
Agency: Austin C. Leebobutra & Staff	
FREED TRANSFORMER CORP.	30
Agency: Franklin Adv. Service	
GERING PRODUCTS, INC.	30
Agency: Ira S. Kahn Co.	
GUARDIAN ELECTRIC	31
Agency: Kennedy & Co.	
HEPPNER MFG. CO.	25
Agency: Burton Browne Advertising	
MEASUREMENTS CORPORATION	28
Agency: Frederick Smith	
MYCALEX CORPORATION OF AMERICA	Inside Front Cover
Agency: George Homer Martin, Associates	
NORTHROP AIRCRAFT, INC.	30
Agency: West-Morris, Inc.	
PRESTOSEAL MFG. CORP.	28
RADIO CORPORATION OF AMERICA	18, 19
Agency: J. Walter Thompson Co.	
RELAY SALES, INC.	32
Agency: A. F. Marthens & Associates	
SPRAGUE ELECTRIC CO.	Back Cover
Agency: The Harry P. Bridge Co.	
U. S. TREASURY DEPT.	Inside Back Cover

WIDE-ANGLE PICKUP RESULTS

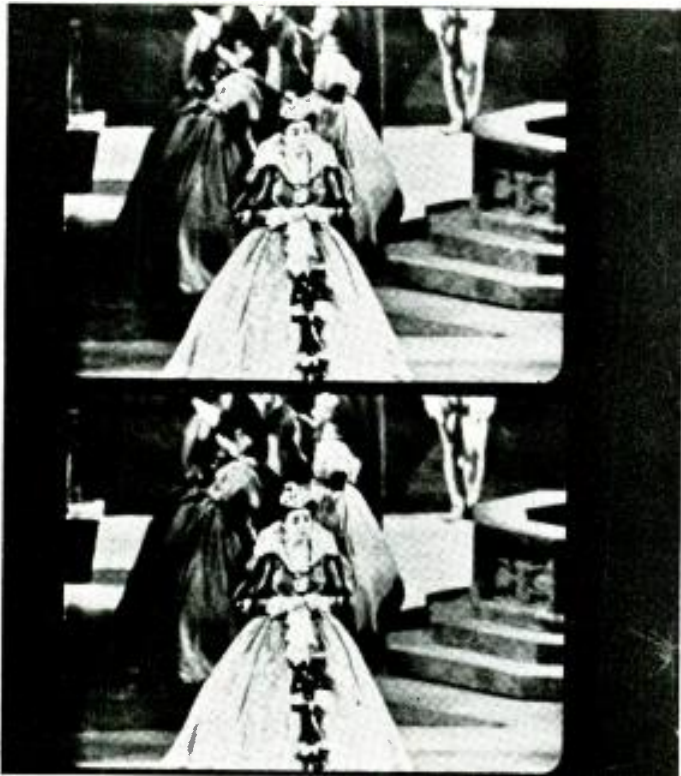

TYPICAL WIDE-ANGLE VIEW obtained during Don Carlos opera telecast. (Courtesy Ed Hamilton, ABC.)

THIS IS IT! THE RELAY

WITH *Interchangeable Coil*
FOR A WIDE RANGE OF RADIO APPLICATIONS

GUARDIAN Series 200

Interchangeable

COIL and CONTACT

Switch Assembly

Two basic parts—a coil assembly and a contact switch assembly—comprise this simple, yet versatile relay. The coil assembly consists of the coil and field piece. The contact assembly consists of switch blades, armature, return spring and mounting bracket. The new Guardian Midget Contact Assembly which is interchangeable with the Standard Series 200 coil assembly, is also available in either single pole, double throw; or double pole, double throw.



CONTACT SWITCH ASSEMBLIES

Cat. No.	Type	Combination	
		Single Pole Double Pole	Double Throw Double Throw
200-1	Standard		
200-2	Standard		
200-3	Contact Switch Parts Kit		
200-4	Standard	Double Pole	Double Throw
200-M1	Midget	Single Pole	Double Throw
200-M2	Midget	Double Pole	Double Throw
200-M3	Midget Contact Switch Parts Kit		

13 COIL ASSEMBLIES

A.C. COILS*			D.C. COILS		
Cat. No.	Volts		Cat. No.	Volts	
200-6A	6 A.C.		200-6D	6 D.C.	
200-12A	12 A.C.		200-12D	12 D.C.	
200-24A	24 A.C.		200-24D	24 D.C.	
200-115A	115 A.C.		200-32D	32 D.C.	
			200-110D	110 D.C.	
			200-5000D		

*All A.C. coils available in 25 and 60 cycles

GUARDIAN ELECTRIC

1615-D W. WALNUT STREET

CHICAGO 12, ILLINOIS

A COMPLETE LINE OF RELAYS SERVING AMERICAN INDUSTRY

Sola Electric Co., 4633 W. 16th St., Chicago 50, Ill., has published a 22-page catalog, *P-17-CF-142*, describing constant voltage transformers. Featured is a cross-reference to transformers and a guide to both standard regulators and four new types.

The Harrington and King Perforating Co., 5655 Fillmore St., Chicago 44, Ill., has released a folder, *Samples of H and K Perforated*, with data and samples of perforated plastic materials. Included are swatches of plastic-coated fabrics, vinyl sheet and film, resin-coated paper and rubber-backed woven plastic fibers.

Insulation Manufacturers Corp., Publications Department, 565 W. Washington Blvd., Chicago 6, Ill., has issued a 12-page catalog describing rag, part-rag, wood-pulp, and rope papers, pressboards and electrical fibre for insulation.

W. Kirchberger and Co., Inc., 1425 37th St., Brooklyn, N. Y., has released two booklets, *Lava Insulators for Electronic Tubes and Lava for Industry*, which describe lava insulators, and include individual specifications, technical properties, grades, thermal resistances.

W. W. Kellogg Co., P. O. Box 169, Jersey City 3, N. J., has issued a technical bulletin, *5-1-52*, describing properties of Kel-F oils, waxes and greases. Oils are said to have lubricating properties which are useful in applications where chemical inertness and resistance to high temperatures are important.

Industry Literature

Lighting and Rectifier Dept., General Electric Co., Schenectady 5, N. Y., has published a 28-page booklet, *GET-2350*, describing the basic characteristics and applications of selenium rectifier stacks. Booklet features charts, graphs and tables illustrating the principles of rectification, and the characteristics, manufacture, circuit design and applications of selenium rectifiers.

Wirt Co., 5231 Greene St., Philadelphia 11, Pa., has issued a bulletin, *177*, describing a line of wire-wound potentiometers, rheostats and slide switches. Potentiometers and rheostats are rated from 3 to 5 watts, made with bakelite housings in values from 5 to 100,000 ohms, and supplied with shaft and bushings as required. Also available from 1.5 to 2 watts in resistance range of 5 to 12,000 ohms.

Heldor Bushing and Terminal Co., 225 Belleville Ave., Bloomfield, N. J., has published a newsletter, with the lead story detailing the painting of the terminal areas of hermetically-sealed transformers.

W. H. Brady Co., Dept. 492, 16 E. Spring St., Chippewa Falls, Wisconsin, has released a 50-page product catalog, describing self-sticking wire markers, pipe markers, safety signs, reflective signs, masks and stencils and printed roll tape.

P. R. Mallory and Co., 3029 E. Washington St., Indianapolis 6, Ind., has prepared a product index which features specific information in condensed form of electrochemical, electromechanical, electronic and metallurgical products. Includes descriptions of batteries, capacitors, contacts, rectifiers, resistors, switches, vibrators, metals and ceramics, tuners and resistance welding supplies.

The Thomas and Betts Co., Inc., 82 Butler St., Elizabeth, N. J., has published a 32-page catalog, *T and B Method Compression Joints for Copper and Aluminum Cable*, bulletin 67, describing aluminum connectors as well as copper fittings. Featured is a table showing government stock numbers and equivalent catalog numbers.

Keystone Carbon Co., St. Marys, Pa., has released an 8-page bulletin, *13*, describing properties, performance characteristics and application information on negative temperature coefficient resistance units.

General Electric Co., Schenectady 5, N. Y., has released a 4-page bulletin, *GEA-5738*, detailing a continuous sampling monitor, a device that is said to simplify quality control.

Mycalex Tube Socket Corp., 60 Clifton Blvd., Clifton, N. J., has prepared data sheets and a catalog covering 7- and 9-pin miniature tube sockets manufactured with Mycalex 40 and 40X insulation. Other products available using these insulators are also described.

Over a Million RELAYS!

This list represents only a small part of more than a million relays in our stock — one of the world's largest. All relays are standard make, brand new in original packing, and fully guaranteed by Relay Sales. Send us your relay requirements. We can make immediate delivery at substantial savings in cost to you.

IMMEDIATE DELIVERY!

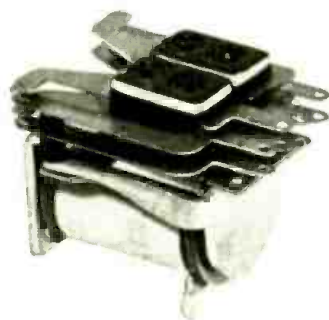
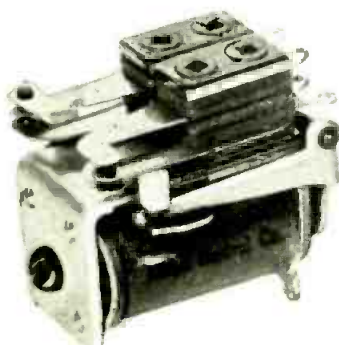
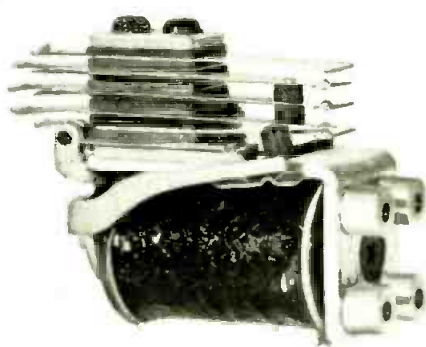

Midget Relays

STK. NO.	VOLTAGE	OHMAGE	CONTACTS	MFG. & NO.	UNIT PRICE
R-416	4 VDC.	9	1C @ 1.5 AMP.	ADVANCE 16035	\$1.65
R-378	6 VDC.	100	1A @ 1.5 AMP.	ADVANCE 16015	1.50
R-850	12 VDC.	450	1A @ 1.5 AMP.	ADVANCE 1601	1.50
R-379	19/27 VDC.	250	2A @ 1.5 AMP.	ADVANCE 1605	1.65
R-694	24 VDC.	300	1A @ 1.5 AMP.	ADVANCE 1601A	1.50
R-935	28 VDC.	1000	1C @ 5 AMP.	ADVANCE 16035	1.65
R-572	24 VDC.	256	1C	AIRCRAFT RADIO CORP.	1.25
R-857	24 VDC.	260	1 MAKE BEFORE MAKE	AIRCRAFT RADIO CORP. 9453	1.75
R-912	4/5 VDC.	20	3A-1C CERAMIC	ALLIED TKX50	1.45
R-291	6 VDC.	5	1A	ALLIED 73A71	1.25
R-921	6.7 VDC.	18	1A Dbl. Brk. @ 10 amp.	ALLIED CRX-11	1.45
R-738	12 VDC.	60	3A	ALLIED TX3A	1.20
R-922	12 VDC.	75	1A Dbl. Brk. @ 10 amp.	ALLIED CRX-13	1.45
R-144	12 VDC.	228	1A	ALLIED D-283486	1.45
R-696	24 VDC.	230	1A @ 8 AMP.	ALLIED 55837	2.00
R-145	18/24 VDC.	250	2A CERAMIC	ALLIED 7252	1.45
R-723	24 VDC.	280	1C	ALLIED 7251	1.50
R-298	21 VDC.	300	1A	ALLIED CB-5	1.25
R-296	21 VDC.	300	1A	ALLIED CA-5	1.25
R-586	21 VDC.	300	1A & 1C	ALLIED 73A-69	1.25
R-142	24 VDC.	400	2C	ALLIED 73A50	1.50
R-785	24 VDC.	200	2C @ 10 AMPS.	AUTO. ELECT. ZH-37169-1	2.00
R-375	24 VDC.	200	2A heavy duty	AUTO. ELECT. H-87063-1	1.75
R-373	12/20 VDC.	225	1A split	AUTO. ELECT. SQA	2.50
R-370	12 VDC.	75	1C	AUTO. ELECT. MANKATO R-25	2.30
R-607	24 VAC.	INT.	1A	AUTO. ELECT. MANKATO R-45-D	1.20
R-606	24 VAC.	INT.	1A & 1B	AUTO. ELECT. MANKATO R-45-F	1.20
R-605	24 VAC.	INT.	3A	AUTO. ELECT. MANKATO R-45-G	1.20
R-374	24 VDC.	300	2A heavy duty	BETTS & BETTS RAC-15AS	1.75
R-728	6 VDC.	30	1A	CLARE A-26690	1.25
R-149	6/8 VDC.	45	1B	CLARE A-20545	1.50
R-732	12 VDC.	120	1A	CLARE A-25454	1.45
R-281	12 VDC.	126	2A	CLARE A-13415	1.25
R-347	18/24 VDC.	300	1A	CLARE A-19469	1.10
R-376	24 VDC.	300	1A	CLARE K	1.25
R-818	18/24 VDC.	300	1B	CLARE A-8058	1.30
R-133	24 VDC.	300	NONE	CLARE A-20388	.75
R-348	18/24 VDC.	300	2A	CLARE A-16734	1.15
R-138	24 VDC.	300	4A	CLARE A-16280	1.45
R-349	18/24 VDC.	300	1C	CLARE B-16947	1.25
R-377	24 VDC.	300	1C	CLARE B-22441	1.45
R-132	24 VDC.	300	2C	CLARE	1.50
R-731	24 VDC.	300	2C	CLARE A-16265	1.55
R-492	24 VDC.	300	4C 1A	CLARE	1.95
R-626	24 VDC.	400	1A @ 5 AMPS.	CLARE A-22717	1.55
R-786	60 VDC.	1300	2C	CLARE A-12408	2.00
R-415	60/85 VDC.	1800	2A	CLARE K	1.95
R-371	2 VDC.	30	1C Ceramic	COOK 418	1.75
R-755	24 VDC.	300	1A	COOK 55340	1.45
R-150	6 VDC.	30	1A	E-Z ELECTRIC	1.50
R-893	14 VDC.	150	1A, 1C	G. E. 55526	2.50
R-895	14 VDC.	150	2A, 1B, 1C	G. E. 55531	2.50
R-896	24 VDC.	260	2A	G. E. 55589	2.50
R-959	24 VDC.	747	2C	GUARDIAN 36761	1.50
R-693	2/6 VDC.	125	1C @ 3 AMP.	LEACH P-501424	1.20
R-947	12/24 VDC.	320	1C @ 3 AMP.	LEACH P-3	1.25
R-692	6/24 VDC.	1280	1C @ 3 AMP.	LEACH P-3	1.35
R-856	18/24 VDC.	300	1B	PAUL HENRY 1010	1.45
R-913	6 VDC.	20	3A, 1C CERAMIC	PRICE BROS.	1.45
R-915	12 VDC.	70	1A Dbl. Brk. @ 10 amp.	PRICE BROS.	2.00
R-148	12 VDC.	100	2C & 1B	PRICE BROS.	1.85
R-222	12 VDC.	100	2A	POTT. & BRUM.	1.00
R-834	6 VDC.	20	3A, 1C	RBM	1.45

OTHER RELAY TYPES IN STOCK

- Keying Relays
- Rotary Relays
- Contactors
- telephone Relays
- Voltage Regulators
- Differential Relays
- Sealed Relays
- Special Relays



Form A—"Make"
(Single Throw,
Normally Open)



Form B—"Break"
(Single Throw,
Normally Closed)



Form C—"Break-Make"
(Double-Throw)



Manufacturers and Distributors:
Write for the new Relay Sales Catalog.

Telephone
SEeley 8-4146

833 W. CHICAGO AVE., DEPT. 12, CHICAGO 22, ILL.

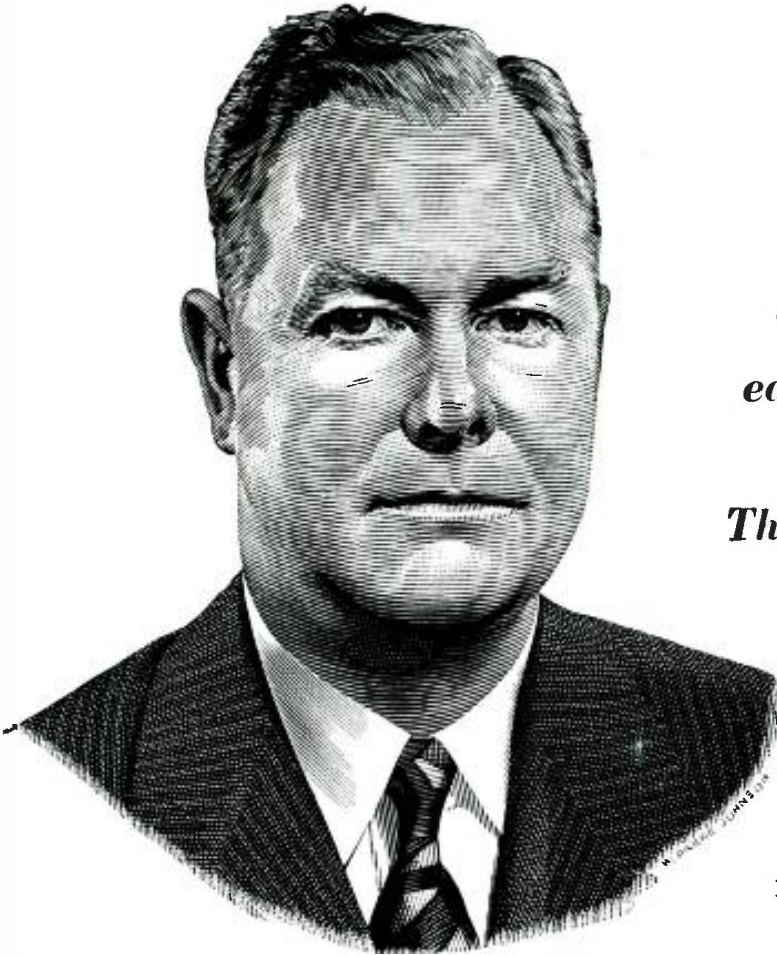

“... Nearly nine out of each ten of our employees are ... participating in The Payroll Savings Plan.”

E. J. HANLEY

President, Allegheny Ludlum Steel Corporation

“Systematic Savings offer the surest means of future security and we know of no better systematic savings plan than that afforded by payroll deduction purchases of U.S. Defense Bonds. Nearly nine out of each ten of our employees are helping their country while they save by participating in this plan.”

There are three easily understood reasons why 88% of Allegheny Ludlum's 14,378 employees are enrolled in the Payroll Savings Plan:

- the recognition by Mr. Hanley and his associates of the Payroll Savings Plan as a major contribution to America's Defense effort . . . an important, stabilizing factor in our national economy . . . a road to personal security for Allegheny Ludlum employees.
- Allegheny Ludlum's person-to-person canvass of employees, which put an application blank for the Payroll Savings Plan in the hands of every man and woman on the company payroll.

- the patriotism and sound sense of the Allegheny Ludlum employees who know that every dollar they invest *each month* in U.S. Defense Bonds is a double duty dollar — it helps to keep America strong . . . it builds personal security for the employee.

If employee participation in *your* Payroll Savings Plan is less than 50% . . . or if you are one of the relatively few industrial companies that does not have a Payroll Savings Plan, phone, wire or write *today* to Savings Bond Division, U.S. Treasury Department, Suite 700, Washington Building, Washington, D.C. You will get all the assistance you may need to place your company among the thousands of companies that have 60, 70, 80%, even 88% participation in the Plan That Protects.

The U. S. Government does not pay for this advertising. The Treasury Department thanks, for their patriotic donation, the Advertising Council and

TELEVISION ENGINEERING



NEW!

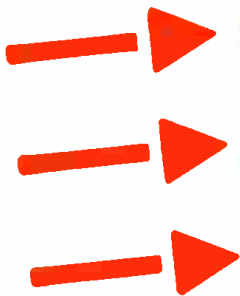

BUTTON CERAMIC CAPACITORS

... FOR TV AND U-H-F DESIGN

Design of electronic equipment and TV receivers for the higher frequencies is simplified by a new series of button ceramic capacitors developed by Sprague. A completely new construction using a disc capacitor element instead of the conventional dielectric tube results in higher self-resonant frequencies and improved circuit efficiency.

For bypass applications, Types 505C, 506C, 507C, and 508C are unique. The dielectric button is housed in a recess in the top of a hex-head machine screw and is sealed against moisture by a plastic resin. This shielded construction minimizes ground inductance and keeps it at a fixed value while providing a short bypass path to ground, which is radially uniform over the capacitor element. The lug terminals are essentially at tube socket terminal height to help maintain short, uniform lead lengths.

Type 501C is a ferrule shank bypass capacitor for push-clip mounting in TV receivers while type 503C is its feed-thru counterpart. The disc capacitor element is resin-sealed in a recess in the top of the metal shell.

Type 502C "shirt-stud" capacitors are $\frac{1}{4}$ " diameter buttons intended for coupling in u-h-f TV set front ends.

All units are rated at 500 volts d-c and are available in both characteristic SL and GA general application bodies.

Engineering Bulletin 605 gives complete details on these new and different capacitors. Request it today on your company letterhead from Sprague Electric Company, North Adams, Mass.

PIONEERS IN ELECTRIC

SPRAGUE

AND ELECTRONIC DEVELOPMENT

NEW HIGH-VOLTAGE CERAMIC DISCS

Sprague Cera-mite Capacitors are now available in 1000 and 1500 volt ratings as well as in the usual 500 volt ratings. Write on letterhead for Bulletin 601C.